

MARGATE COMMUNITY REDEVELOPMENT AGENCY

RESOLUTION NO. 675

A RESOLUTION OF THE MARGATE COMMUNITY REDEVELOPMENT AGENCY, AUTHORIZING A WAIVING OF BID AND AWARD OF DESIGN/BUILD CONTRACT TO MBR CONSTRUCTION, INC. AS A PIGGYBACK OF BROWARD COUNTY PURCHASING CONTRACT (PARK IMPROVEMENTS AND CONSTRUCTION) FOR RENOVATIONS TO SERINO PARK IN THE AMOUNT NOT TO EXCEED \$1,265,000; PROVIDING FOR AN EFFECTIVE DATE.

BE IT RESOLVED BY THE BOARD OF THE MARGATE COMMUNITY REDEVELOPMENT AGENCY OF MARGATE, FLORIDA:

SECTION 1: That the Board of the Margate Community Redevelopment Agency hereby authorizes a waiving of bid and award of Design/Build contract to MBR Construction, Inc. as a piggyback of Broward County Purchasing Contract (Park Improvements and Construction) for renovations to Serino Park, at a total contract price not to exceed One Million Two Hundred Sixty-Five Thousand Dollars (\$1,265,000).

SECTION 2: That the Chairman and Executive Director are hereby authorized and directed to execute said agreement on behalf of the Margate Community Redevelopment Agency, a copy of which is attached hereto and specifically made a part of this resolution as Attachment "A".

SECTION 3: That this Resolution shall become effective immediately upon its passage.

PASSED, ADOPTED, AND APPROVED THIS 13th day of October, 2021.



Chair Tommy Ruzzano

RECORD OF VOTE

Simone	<u>YES</u>
Arserio	<u>YES</u>
Schwartz	<u>YES</u>
Caggiano	<u>YES</u>
Ruzzano	<u>YES</u>

AGREEMENT

THIS CONTRACT, made and entered into this 13 day of October, 2021 ("Effective Date"), by and between: MARGATE COMMUNITY REDEVELOPMENT AGENCY, located at 5790 Margate Boulevard, Margate, Florida 33063, a dependent special district, (hereinafter referred to as "MCRA"); and MBR CONSTRUCTION, INC., a Florida corporation located at 1020 NW 51st Street, Ft. Lauderdale, Florida 33309 (hereinafter referred to as "CONTRACTOR").

WITNESSETH:

IN CONSIDERATION of the mutual covenants and conditions as herein expressed and of the faithful performance of all such covenants and conditions, the parties do mutually agree as follows:

ARTICLE I

THE CONTRACT DOCUMENTS

The Contract Documents consist of all of the following: CONTRACTOR's Proposal, dated August 20, 2021, attached hereto as Exhibit "A"; Pricing Schedule on existing agreement between CONTRACTOR and Broward County - #PNC2120194B1 ("County Agreement"), attached hereto as Exhibit "B"; Broward County Contract Award Letter, attached hereto as Exhibit "C"; and Serino Park Restroom Building and Park Improvements Design-Build Criteria Package summary along with Serino Park Site Plan, Serino Park Topographic Survey, and Fitness Court Rendering with Slab Installation dimensions and specifications, attached hereto as Exhibit "D"; all of which are made a part of this contract, or any additional documents which are required to be submitted under the Contract, and all amendments, modifications and supplements issued on or after the effective date of the Contract. For purposes of this Agreement, all references to "Broward County" in the County Agreement and County Award Letter shall be replaced with the "City of Margate Community Redevelopment Agency".

ARTICLE 2

SCOPE OF THE WORK

CONTRACTOR shall furnish all of the labor, materials, equipment, transportation, supplies, and services necessary to perform all of the work required by the Contract Documents, including shop drawings and other items required for permitting for:

SERINO PARK RESTROOM BUILDING AND PARK IMPROVEMENTS

ARTICLE 3

CONTRACT TIME

TIME IS OF THE ESSENCE OF THIS CONTRACT. CONTRACTOR shall cause the preparation of design drawings and permit applications to commence within fifteen (15) calendar days of the execution of this Contract and to diligently pursue completion of the design drawings and obtaining all permits required to perform the work required by this Contract. Upon notification of receipt of all required permits, MCRA shall issue a Notice to Proceed. The work to be performed under this Contract shall be commenced upon the date of Contract Commencement specified in the Notice to Proceed and, subject to authorized adjustments, shall be totally complete and ready for final payment within two hundred and forty (240) days from the date of Contract Commencement. Failure to achieve timely final completion shall be regarded as a breach of this Contract and subject to appropriate remedies.

ARTICLE 4

CONTRACT SUM

1. THIS IS A LUMP SUM CONTRACT. MCRA shall pay to CONTRACTOR the amount of One Million, Two Hundred and Sixty-Five Thousand Dollars (\$1,265,000).
2. The CONTRACT Amount includes \$115,000 (10%) of Contingency Funds for permit fees and other additional costs approved by the MCRA. Upon completion of the project, unused Contingency Funds may, at the MCRA's option, be applied to maintenance costs, additional tasks and/or credited to the MCRA.
3. CONTRACTOR may requisition payment for Work completed during the Project at intervals of not more than once per month.
4. Payment shall be made consistent with paragraphs 1, 2, and 3 herein and shall be subject to retainage of 10% until all Work is completed. This price shall be full compensation for all costs associated with completion of all the work in full conformity with the requirements of this agreement including Exhibits, attached hereto.

ARTICLE 5

PAYMENT

1. The CONTRACTOR shall requisition payment in accordance with the terms set forth in Article 4 above. Requisition for payment shall include properly executed releases of liens by all

subcontractors, suppliers and materialmen as may be required by MCRA. Upon receipt of requisition and any required releases, MCRA shall make payment to CONTRACTOR within 30 calendar days after receipt.

2. MCRA may withhold, in whole or in part, payment to such extent as may be necessary to protect itself from loss on account of:
 - a. Defective work not remedied.
 - b. Claims filed or unreasonable evidence indicating the probable filing of claims by other parties against the CONTRACTOR.
 - c. Failure of the CONTRACTOR to make payment to subcontractors or suppliers for materials or labor.
 - d. Damage to the MCRA or to another contractor not remedied. Contractor shall be responsible to repair all damage caused by Contractor.
 - e. Reasonable evidence that the work cannot be completed for the unpaid balance of the Contract time.
 - f. Reasonable evidence that the work will not be completed within the Contract Time.
 - g. Persistent failure to carry out the work in accordance with the Contract Documents.

When the above conditions are resolved, CONTRACTOR provides a surety bond, or a consent of surety satisfactory to the MCRA with the intent to protect the MCRA in the amount withheld, payment may be processed. Notwithstanding anything to the contrary herein, if the MCRA in its sole discretion determines not to proceed with the installation portion of the Scope of Work prior to the second payment due hereunder, the MCRA may terminate the Contract upon written notice to CONTRACTOR. Upon such notice, CONTRACTOR shall immediately cease all work. MCRA shall pay CONTRACTOR for costs incurred prior to termination in excess of prior payments.

ARTICLE 6

FINAL PAYMENT

Final payment, constituting the entire unpaid balance of the Contract Sum, shall be paid by the MCRA to the CONTRACTOR when all outstanding work has been completed and all controversy as outlined in Article 5 has been settled to the MCRA'S satisfaction, not to be unreasonably withheld.

ARTICLE 7

MISCELLANEOUS PROVISIONS

NO WAIVER OF SOVEREIGN IMMUNITY

Nothing herein is intended to serve as a waiver of sovereign immunity by any agency or political subdivision to which sovereign immunity may be applicable or of any rights or limits to liability existing under Section 768.28, Florida Statutes. This section shall survive the termination of all performance or obligations under this Agreement and shall be fully binding until such time as any proceeding brought on account of this Agreement is barred by any applicable statute of limitations.

NO THIRD PARTY BENEFICIARIES

The parties expressly acknowledge that it is not their intent to create or confer any rights or obligations in or upon any third person or entity under this Agreement. None of the parties intend to directly or substantially benefit a third party by this Agreement. The parties agree that there are no third party beneficiaries to this Agreement and that no third party shall be entitled to assert a claim against any of the parties based upon this Agreement. Nothing herein shall be construed as consent by an agency or political subdivision of the State of Florida to be sued by third parties in any matter arising out of any Agreement.

INDEPENDENT CONTRACTOR

The parties to this Agreement shall at all times be acting in the capacity of independent contractors and not as an officer, employee or agent of one another. Neither party nor its respective agents, employees, subcontractors or assignees shall represent to others that it has the authority to bind the other party unless specifically authorized in writing to do so. No right to retirement, leave benefits or any other benefits of either party's employees shall exist as a result of the performance of any duties or responsibilities under this Agreement. Neither party shall be responsible for social security, withholding taxes, contributions to unemployment compensation funds or insurance for the other party or the other party's officers, employees, agents, subcontractors or assignees.

NOTICE

When any of the parties' desire to give notice to the other, such notice must be in writing, sent by U.S. Mail, postage prepaid, addressed to the party for whom it is intended at the place last specified. The place for giving notice shall remain such until it is changed by written notice in compliance with the provisions of this paragraph. For the present, the Parties designate the following as the respective places for giving notice:

To MCRA: Cale Curtis, Executive Director
Margate CRA
5790 Margate Blvd.
Margate, FL 33063

To CONTRACTOR: Michael Boss, President
MBR Construction, Inc.
1020 NW 51st Street
Ft. Lauderdale, FL 33309

PUBLIC RECORDS

This Agreement and this Addendum shall be subject to Florida's Public Records Laws, Chapter 119, Florida Statutes. Contractor understands the broad nature of these laws and agrees to comply with Florida's public records laws and laws relating to records retention. In compliance with section 119.0701, Florida Statutes, Contractor agrees to:

- a. CONTRACTOR agrees to keep and maintain public records in CONTRACTOR's possession or control in connection with CONTRACTOR's performance under this Agreement. CONTRACTOR additionally agrees to comply specifically with the provisions of Section 119.0701, Florida Statutes.
- b. CONTRACTOR shall ensure that public records that are exempt or confidential and exempt from public records disclosure requirements are not disclosed, except as authorized by law, for the duration of the Agreement, and following completion of the Agreement until the records are transferred to MCRA.
- c. Upon request from MCRA custodian of public records, CONTRACTOR shall provide MCRA with a copy of the requested records or allow the records to be inspected or copied within a reasonable time at a cost that does not exceed the cost provided by Chapter 119, Florida Statutes, or as otherwise provided by law.
- d. Unless otherwise provided by law, any and all records, including but not limited to reports, surveys, and other data and documents provided or created in connection with this Agreement are and shall remain the property of MCRA.
- e. Upon completion of this Agreement, transfer, at no cost, to the MCRA all public records in possession of CONTRACTOR or keep and maintain public records required by MCRA to perform the service. If CONTRACTOR transfers all public records to MCRA upon completion of this Agreement, CONTRACTOR shall destroy any duplicate public records that are exempt or confidential and exempt from public records disclosure requirements. If CONTRACTOR keeps and maintains public records upon completion of this Agreement, CONTRACTOR shall meet all applicable requirements for retaining public records. All records stored electronically by CONTRACTOR shall be delivered to MCRA, upon request from the MCRA's Custodian of Records, in a format that is compatible with the MCRA's information technology systems.

- f. Any compensation due to CONTRACTOR shall be withheld until all records are received as provided herein.
- g. CONTRACTOR's failure or refusal to comply with the provisions of this section shall result in the immediate termination of this Agreement by MCRA.

IF CONTRACTOR HAS QUESTIONS REGARDING THE APPLICATION OF CHAPTER 119, FLORIDA STATUTES, TO CONTRACTOR'S DUTY TO PROVIDE PUBLIC RECORDS RELATING TO THIS CONTRACT, CONTACT THE CUSTODIAN OF PUBLIC RECORDS.

Custodian of Public Records:	CITY CLERK
Mailing address:	5790 Margate Blvd., Margate, FL 33063
Telephone number:	954-935-5327
Email:	CityClerk@margatefl.com

GOVERNING LAW AND VENUE

This Agreement shall be interpreted and construed in accordance with and governed by the laws of the State of Florida. Any controversies or legal problems arising out of this Agreement and any action involving the enforcement or interpretation of any rights hereunder shall be submitted to the jurisdiction of the State courts of the Seventeenth Judicial Circuit of Broward County, Florida.

SCRUTINIZED COMPANIES.

CONTRACTOR certifies that it and any of its affiliates are not scrutinized companies as identified in Section 287.135, Florida Statutes. In addition, CONTRACTOR agrees to observe the requirements of Section 287.135, Florida Statutes, for applicable sub-agreements entered into for the performance of work under this agreement. Pursuant to Section 287.135, Florida Statutes, the MCRA may immediately terminate this agreement, for cause, if the CONTRACTOR, its affiliates, or its subcontractors are found to have submitted a false certification; or if the CONTRACTOR, its affiliates, or its subcontractors are placed on any applicable scrutinized companies list or engaged in prohibited contracting activity during the term of the agreement. As provided in Subsection 287.135(8), Florida Statutes, if federal law ceases to authorize these contracting prohibitions then they shall become inoperative.

AUTHORITY

Each person signing this Agreement on behalf of either party individually warrants that he or she has full legal power to execute this Agreement on behalf of the party for whom he or she is signing, and to bind and obligate such party with respect to all provisions contained in this Agreement.

COMPLIANCE WITH LAWS

Each party shall comply with all applicable federal, state and local laws, codes, rules and regulations in performing its duties, responsibilities and obligations pursuant to this Agreement.

ENTIRETY OF AGREEMENT

This document incorporates and includes all prior negotiations, correspondence, conversations, agreements and understandings applicable to the matters contained herein and the parties agree that there are no commitments, agreements or understandings concerning the subject matter of this Agreement that are not contained in this document. Accordingly, the parties agree that no deviation from the terms hereof shall be predicated upon any prior representations or agreements, whether oral or written.

ASSIGNMENT.

Neither this Agreement nor any interest herein may be assigned, transferred or encumbered by any party without the prior written consent of the other party. There shall be no partial assignments of this Agreement.

PREPARATION OF AGREEMENT

The parties acknowledge that they have sought and obtained whatever competent advice and counsel as was necessary for them to form a full and complete understanding of all rights and obligations herein and that the preparation of this Agreement has been their joint effort. The language agreed to herein expresses their mutual intent and the resulting document shall not, solely as a matter of judicial construction, be construed more severely against one of the parties than the other.

AMENDMENTS

No modification, amendment, or alteration in the terms or conditions contained herein shall be effective unless contained in a written document prepared with the same or similar formality as this Agreement and executed by each party hereto.

SURVIVAL

All representations and warranties made herein, indemnification obligations, obligations to maintain and allow inspection and audit of records and property, and obligations to maintain the confidentiality of records shall survive the termination of this Agreement.

COUNTERPARTS AND MULTIPLE ORIGINALS

This Agreement may be executed in multiple originals, and may be executed in counterparts, each of which shall be deemed to be an original, but all of which, taken together, shall constitute one and the same Agreement.

[THE REMAINDER OF THIS PAGE HAS BEEN INTENTIONALLY LEFT BLANK;
SIGNATURE PAGE TO FOLLOW]

IN WITNESS WHEREOF, the parties have hereunto set their hands and seals the day and year first above written.

MARGATE COMMUNITY REDEVELOPMENT AGENCY (MCRA)



Tommy Ruzzano, Chair

13 day of OCTOBER, 2021



Cale Curtis, Executive Director

13 day of OCTOBER, 2021

WITNESS:



Rita Rodi, CRA Coordinator

13 day of OCTOBER, 2021

APPROVED AS TO FORM:



David N. Tolces, MCRA Board Attorney

13 day of OCTOBER, 2021

FOR CONTRACTOR

FOR CORPORATION:



Michael Boss, President

5 day of October, 2021

(CORPORATE SEAL)

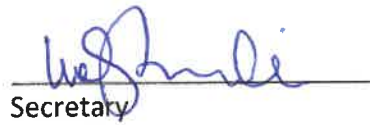

Secretary

5 day of October, 2021

EXHIBIT A



The Experience You Need... The Honesty You Expect.

August 20, 2021

Arlene Walcott, AICP
Margate Community Development Agency
5790 Margate Boulevard
Margate, FL 33063

Ref: Serino Park Renovations
Sub: Design/Build Budgetary Proposal, Piggyback Method of Contracting

Arlene,

Thank you for the opportunity to offer our proposal for this project. The proposal is based on the Design Criteria and supporting documents you provided along with our site visits. We structured our proposal around the Broward County Parks Construction and Improvements term contract with the intention of utilizing the Piggyback method of contracting for the project. Under a separate cover, we will transfer all the necessary documentation for Broward County Solicitation No. PNC2120194B1, Parks Construction and Improvements term contract to facilitate the process.

Scope of work per the Design Criteria:

1. Single stall male, single stall female restroom facility, with janitor's closet, and attached or adjacent drinking fountain/bottle filler where shown on Exhibit 1. Exterior bathroom walls to have stone veneer, about 50% from ground level. \$162,500.
*Offeror shall also include as a bid alternate a double stall (two (2) female stalls and two (2) male stalls).
*\$250,000.
2. Remove existing playground equipment, shade canopies, sand surfacing, curbing. \$27,400
3. Install all new playground equipment with 100% shade covering, accessible safety surfacing, and lighting. The playground area shall be reduced to the approximate size as shown on Exhibit 1. (including ages 2-5 and 5-12 equipment groups) \$400,765.
4. All pervious areas of the Park shall be resodded with St. Augustine Floratam Grade A sod. \$35,790.
5. Offeror to construct slab and install shade canopy (100% coverage) over the proposed fitness court and shall install all fitness equipment, to be provided by City or CRA. \$70,625.
6. Seal coat and restripe the existing parking lot. \$10,200.
7. Demolish existing pavilion and install new 20' x 30' pavilion at existing location. (CRA or City will furnish and Offeror shall install 4 tables with benches). Contractor will also install electrical service to the pavilion and include one GFI outlet and security lighting. (included BC Contract equivalent item is 24' X 24') \$59,000
8. Add 12 Royal Palm trees (20' overall height) at southern property line with decorative up-lighting; add decorative up-lighting to existing trees. No Sabal Palms are to be installed and existing Sabal Palms (if any) shall be removed. \$48,000
9. Grading, drainage, hardscape, landscape, irrigation and utilities associated with the above improvements. \$115,160.
- 10 Other: Design Fee \$85,000, General Conditions \$122,915, Bond \$12,645,

Grand total for the above is \$1,150,000.

Thanks again for the opportunity to work with the City of Margate on this project.

Ed Broccoli
Estimator

Copy: Mike Boss, Federica Douaihi

Broward County Bid/Contract No. PNC2120194B1 Parks Construction and Improvements

MBR Project Name: Design-Build Serino Park Renovation

MBR Project Number: PM08232101

Proposal Date: August 30, 2021

Prepared by: Ed/MBR for City of Margate CRA

Preparation Date: Use latest revision date

Project Location: Serino Park

Project Title: Design-Build Serino Park Renovations



Bid Line Item No PNC2120194B1	Full bid/contract item description from BidSync	Estimated Quantities	Unit	MBR Construction, Inc.	
				Unit Price	Total Unit Price
01 01	Provide unsuitable, non-contaminated materials removal and legal disposal such as muck (Playground sand)	415	cubic yard	\$66.72	\$27,688.80
01 02	Provide structural fill for building pads placed and compacted in 12 Inch lifts	20	cubic yard	\$23.40	\$468.00
02 07	Provide Prototype Restroom Building with Janitor per Drawings and Project Manual Section 01 22 00 (square foot calculation of proposed building vs. prototype building)	0.68	lump sum	\$239,046.00	\$162,551.28
05 01	Provide Mirade Playground A Ages 2-5 (Large) per Drawing with footings and all other requirements of Project Manual Divisions 11 and 13; shade structure and surfacing are not included in the cost	1	lump sum	\$69,240.42	\$69,240.42
05 04	Provide Mirade Playground D Ages 5-12 (Large) per Drawing with footings and all other requirements of Project Manual Divisions 11 and 13; shade structure and surfacing are not included in the cost	1	lump sum	\$98,408.48	\$98,408.48
06 01	Provide square 24 x 24 feet prefabricated shelter with concrete footings and other requirements per Project Manual Division 13.	1	lump sum	\$38,002.80	\$38,002.80
06 12	Provide 30 x 30 x 12 feet eave height hipped shade structure with concrete footings per per Project Manual Division 13. (At Fitness)	1	lump sum	\$22,698.00	\$22,698.00
06 14	Provide 40 x 40 x 12 feet eave height hipped shade structure with concrete footings per per Project Manual Division 13. (At Playground)	2	lump sum	\$28,240.80	\$56,481.60
08 11	Provide LED Flood Light, 5700K, Skyler SKT-MT-FL-70/90/110 or approved equal (12 new trees + ?? Extg)	24	each	\$503.22	\$12,077.28
08 21	Provide Meter Can 200 Amp, 250V single phase or 600V three phase	1	each	\$647.94	\$647.94
08 23	Provide Disconnect Switch, NEMA 4X, 100 Amp, 250V single phase	1	each	\$2,582.40	\$2,582.40
08 26	Provide 100 to 200 Amp Panel Board, 120/240V single phase	1	each	\$3,582.00	\$3,582.00
08 30	Provide Grounding Electrode, No. 2 with 0.75 inch x 10 feet, copper-clad ground rod	3	each	\$138.28	\$414.84
08 31	Provide Pull and Junction Boxes, concrete, traffic-rated	2	each	\$574.80	\$1,149.60
08 32	Provide 20 Amp Circuit Breaker, 250 V, 1 pole, 10K IC	6	each	\$99.60	\$597.60
08 39	Provide 30A electrical service feeder with 4 No. 10 THWN, 1 No. 8 THWN ground	800	linear foot	\$4.62	\$3,696.00
08 40	Provide 40A electrical service feeder with 4 No. 8 THWN, 1 No. 8 THWN ground	100	linear foot	\$5.62	\$562.00
08 45	Provide 200A electrical service feeder with 4 No. 3/0 THWN, 1 No. 4 THWN ground	100	linear foot	\$24.18	\$2,418.00
08 48	Provide Conduit, 0.75 to 1 inch PVC, schedule 40, Underground, 24 inch depth	1000	linear foot	\$9.77	\$9,770.00
08 54	Provide Conduit, 1 inch dia. GRC	20	linear foot	\$10.69	\$213.80
08 55	Provide Conduit, 2 inch dia. GRC	20	linear foot	\$22.10	\$442.00
09 01	Provide 14-1 Direct Burial, 24VAC Signal Wire Irrigation Electric per Project Manual Divisions 26 and 32	400	linear foot	\$0.38	\$152.00
09 08	Provide Epoxy Wire Splice with Electric Splice Box per Project Manual Divisions 26 and 32	6	each	\$15.60	\$93.60
11 26	Furnish and Install Temporary Galvanized Chain Link Fence, 6 feet high for 90 day period	1500	linear foot	\$3.00	\$4,500.00
11 43	Provide Landscaping Trees Price Group D, see Project Manual Division 32	215	linear foot	\$67.20	\$14,448.00

11 54	Provide St. Augustine Sod, see Project Manual Division 32	54222	square foot	\$0.66	\$35,786.52
11 60	Furnish and apply Fertilizer, Herbicides or Insecticides to new landscaping, minimum quantity is one hour. See Project Manual Division 32.	8	hour	\$120.00	\$960.00
11 61	Provide Additional Watering after Final Completion of new landscaping, see Project Manual Division 32	800	gallons	\$0.55	\$440.00
11 68	Provide Poured-in-place EPDM for 6 feet fall height per Project Manual Division 32; excludes the cost for subbase (asphalt, concrete or aggregate)	9000	square foot	\$15.49	\$139,410.00
13 01	12 inch shrub adapter with nozzle with pressure regulation and pre-installed nozzle, with schedule 80 riser per Project Manual Division 32, Toro 570 or 570 PRX or approved equal, furnish and install	12	each	\$24.50	\$294.00
13 07	12 inch pop-up with in-stem shut-off device built into the riser and one-piece check valve with funny pipe assembly per Project Manual Division 32, Toro 570Z Series XF or approved equal, furnish and install	12	each	\$22.75	\$273.00
13 10	Bubbler with radius adjustment up to 50 percent, attaches directly to risers, with funny pipe assembly and schedule 80 Riser per Project Manual Division 32. Toro 500 Series bubbler or approved equal, furnish and install	12	each	\$7.58	\$90.96
13 11	5 inch pop-up rotor equal to Toro TR50P with with plastic pipe fitting, 0.75 inch x 12 inch Prefabricated Swing Joint per Project Manual Division 32, furnish and install	12	each	\$30.00	\$360.00
13 12	4 inch pop-up rotor equal to Toro TS90 with with plastic pipe fitting, 1 inch x 10 inch Prefabricated Swing Joint per Project Manual Division 32, furnish and install	12	each	\$131.45	\$1,577.40
13 19	1.5 inch Electrical Valve with bronze irrigation gate valve, Toro P220-26-04 or approved equal, with gate valve and cement valve box, furnish and install per Project Manual Division 32	6	each	\$312.00	\$1,872.00
13 25	2 inch Bronze Gate Valve with Cement Valve Box with bronze irrigation gate valve furnish and install per Project Manual Division 32	2	each	\$270.00	\$540.00
13 30	Toro TDC Series 2-Wire System CDEC-SA-100 Irrigation Controller or approved equal furnish and install per Project Manual Division 32	1	each	\$2,931.30	\$2,931.30
13 37	Furnish and install Wireless Rain Sensor, adjustable rain sensitivity, Toro TWRS or approved equal	1	each	\$148.03	\$148.03
11 71	0.75 inch Schedule 40 PVC solvent weld lateral pipe, 18 inch depth with Schedule 40 fittings, furnish and install	250	linear foot	\$2.76	\$690.00
11 72	1 to 1.5 inch Schedule 40 PVC solvent weld lateral pipe, 18 inch depth with Schedule 40 fittings, furnish and install	249	linear foot	\$3.60	\$896.40
11 73	2 to 3 inch Schedule 40 PVC solvent weld lateral pipe, 18 inch depth with Schedule 40 fittings, furnish and install	250	linear foot	\$6.30	\$1,575.00
11 81	2 to 3 inch Electrical Wire Sleeve, furnish and install	20	linear foot	\$3.60	\$72.00
11 82	4 inch schedule 40 Pipe Sleeve, furnish and install	20	linear foot	\$2.11	\$42.20
12 07	FDOT No. 104 10 3 Sediment Barrier	1404	linear foot	\$0.82	\$1,151.28
12 10	FDOT No. 104 18 Inlet Protection System	9	each	\$60.00	\$540.00
12 11	FDOT No. 110 1 1 Standard Clearing and Grubbing including trash and debris removal referenced in Section 01 42 00 (includes site wide major demolitions items)	12000	square yard	\$1.80	\$21,600.00
12 12	FDOT No. 110 4 A Remove Existing Pavement or Concrete per FDOT Standards and FDOT Design Standards referenced in Section 01 42 00	100	square yard	\$9.60	\$960.00
12 14	FDOT No. 120-1 Regular Excavation per FDOT Standards and FDOT Design Standards referenced in Section 01 42 00 (includes major earthwork items)	4000	cubic yard	\$7.80	\$31,200.00
12 16	FDOT No. 120-6 Embankment per FDOT Standards and FDOT Design Standards referenced in Section 01 42 00	100	cubic yard	\$12.00	\$1,200.00

12 19	FDOT No. 160-4 Subgrade Stabilization per FDOT Standards and FDOT Design Standards referenced in Section 01 42 00	900	square foot	\$6.00	\$5,400.00
12 21	FDOT No. 162-1-21 Prepared Organic Soil Layer, 6 inches per FDOT Standards and FDOT Design Standards referenced in Section 01 42 00	6024	square yard	\$10.20	\$61,444.80
12 22	Washed Rock No. 68 (3/4 inch), formerly FDOT No. 901	43	ton	\$27.53	\$1,183.79
12 24	FDOT No. 285-712 Optional Base Group, Group 6 (12 Inch limerock) per FDOT Standards and FDOT Design Standards referenced in Section 01 42 00 (Sub for base under play surface)	900	square yard	\$32.47	\$29,223.00
12 31	FDOT No. 400-1-15 Class I Miscellaneous Concrete per FDOT Standards and FDOT Design Standards referenced in the Project Manual Section 01 42 00 (for Fitness area slab)	50	cubic yard	\$210.00	\$10,500.00
12 41	FDOT No. 520-2-4 Concrete Curb Type D	55	linear foot	\$21.60	\$1,188.00
12 42	FDOT No. 522-1 4 inch thick Concrete Sidewalk including subgrade construction	28	square yard	\$54.00	\$1,512.00
12 49	FDOT No. 710 Removal of 6 inch painted striping	465	linear foot	\$21.60	\$10,044.00
12 50	FDOT No. 710 Painted Directional Arrows (includes handicap messages)	6	each	\$54.00	\$324.00
12 53	FDOT No. 710 Painted 18 inch Solid Traffic Stripe (at handicap chevron)	50	linear foot	\$1.56	\$78.00
12 54	FDOT No. 710 Painted 24 inch Solid Traffic Stripe	12	linear foot	\$3.60	\$43.20
12 86	Provide Sloped Concrete Car Stop, 6 feet long x 8 inch wide x 5 inch high with 2 rebar pegs in gray, white or yellow color	22	each	\$40.80	\$897.60
14 11	Provide 6 inch Water Sewer Main Tapping Sleeve and Valve per Broward County WWS Minimum Design & Construction Standards	1	assembly	\$5,640.00	\$5,640.00
14 32	Provide Water Service Connection, 1 Inch, Type 1 with corporation stop per Broward County WWS Minimum Design & Construction Standards	1	each	\$1,170.00	\$1,170.00
14 34	Provide 1 inch Above Ground backflow preventer vault (RPZ)	1	each	\$1,600.80	\$1,600.80
14 39	Provide Sewer Service, 6 inch, PVC, ASTM 3034, SDR-26 per Broward County WWS Minimum Design & Construction Standards	150	linear foot	\$30.00	\$4,500.00
14 43	Provide Clean-out, 4 inch PVC with Cast Iron Valve box and 12 inch x 12 inch x 6 inch Concrete Collar	2	each	\$318.00	\$636.00
15 01	Site Grading Crew Includes all labor, equipment and travel; minimum quantity is one hour.	24	hour	\$300.00	\$7,200.00
	Construction Laborer not included in the other line items or for expedited schedules; usage requires written justification and pre-approval by the Contract Administrator; minimum quantity is one hour; includes equipment and travel.	795	hour	\$25.75	\$20,471.25
15 03	Provide details/assumptions: Misc labor not included in other line items				
	Licensed and Insured Electrical Journeyman or Electrician not included in the other line items or for expedited schedules; usage requires written justification and pre-approval by the Contract Administrator or designee; minimum quantity is one hour. Includes equipment and travel.	162	hour	\$96.00	\$15,552.00
15 04	Provide details/assumptions: Misc Electrician labor not included in other line items				
15 05	Dump Truck, 16 to 19 CY capacity and includes Operator, fuel, insurance and delivery. Minimum quantity is one hour.	15	day	\$480.00	\$7,200.00
15 06	Backhoe for Excavating and Burying of Underground Installations with Operator, fuel, insurance and delivery. Minimum quantity is one hour.	160	hour	\$128.75	\$20,600.00
All	Miscellaneous Construction Materials and Services; retainage applies Provide details/assumptions: Includes Bond @ \$12,645, General Conditions not included in the line item 16 01 below; 5% limitation @ \$5,355		lump sum		\$18,000.00
	Subtotal				\$1,001,904.97

16 01	General Conditions in accordance with Section 01 21 00 of the Project Manual and the Special Instructions to Vendors. Maximum amount is 5.00%. General Conditions applies to all line items and the Provide Miscellaneous Construction Materials and Services pass-thru only; per Project Manual Section 01 21 00 Paragraphs 1.2 and 3.1	\$50,095.25
Spec Instr L.3 and 01 21 00	Permit and Inspection Fees, Unforeseen Conditions and Utility Connection Fees per Project Manual Section 01 21 00 Paragraphs 1.2 and 2.1 Provide details/assumptions: Estimated Non-Margate agency fees	\$5,000.00
Spec Instr L.3 and 01 21 00	Non-CCNA Professional Services and Geotechnical Testing Services per Project Manual Section 01 21 00 Paragraph 1.3 Provide details/assumptions: Design Fees @ \$85,000, Geotech and other testing @ \$8,000	\$93,000.00
Estimated Total		\$1,150,000.22

County Project Estimate Form First Term 081120

Prices in blue were a voluntary price reduction offered by Vendor prior to recommendation for award

Numbering for Group 12 corrected on 8/11/20

PROPOSAL NOTES:

1. This proposal represents the budgetary value of the project scope interpreted into the available line items. See line item parentetical notes.
2. This is a Design-Build proposal. Line items and quantities are assumed and will change with development of a project plan.

MBR CONSTRUCTION, INC.

Bid Contact Ron Boss
ebroc@mbrconstruction.com
Ph 954-486-8404
Fax 954-486-9579

Address 1020 NW 51st Street
FORT LAUDERDALE, FL 33309

Bid Bond  (Status: Authorized on May 20, 2020)

Item #	Line Item	Notes	Unit Price	Qty/Unit	Attch. Docs
PNC2120194B1-01-01	Miscellaneous: Unsuitable Soil Materials Removal	Supplier Product Code:	First Offer - \$66.72	20 / cubic yard	\$1,334.40 Y Y
PNC2120194B1-01-02	Miscellaneous: Structural Fill	Supplier Product Code:	First Offer - \$23.40	150 / cubic yard	\$3,510.00 Y
PNC2120194B1-01-03	Miscellaneous: Precast Concrete Basketball Standard	Supplier Product Code:	First Offer - \$15,000.00	2 / lump sum	\$30,000.00 Y
PNC2120194B1-01-04	Miscellaneous: Tennis Netting and Anchoring Standard	Supplier Product Code:	First Offer - \$360.00	2 / lump sum	\$720.00 Y
PNC2120194B1-01-05	Miscellaneous: Aluminum Handrails and Railings	Supplier Product Code:	First Offer - \$83.94	125 / linear foot	\$10,492.50 Y
PNC2120194B1-01-06	Miscellaneous: Aluminum Handrails and Railings	Supplier Product Code:	First Offer - \$83.94	25 / linear foot	\$2,098.50 Y

Bid Allowance

\$600,000.00

Lot Total **\$48,155.40**

Item #	Line Item	Notes	Unit Price	Qty/Unit	Attch. Docs
PNC2120194B1-02-01	Custom Structures: Prototype Small Picnic Shelter	Supplier Product Code:	First Offer - \$64,738.80	1 / lump sum	\$64,738.80 Y
PNC2120194B1-02-02	Custom Structures: Upgrade of Shelter	Supplier Product Code:	First Offer - \$576.00	1 / lump sum	\$576.00 Y
PNC2120194B1-02-03	Custom Structures:	Supplier	First Offer - \$81,228.00	1 / lump sum	\$81,228.00 Y

Prototype Medium
Picnic Shelter **Product
Code:**

PNC2120194B1-02-04	Custom Structures: Upgrade of Shelter	Supplier Product Code:	First Offer - \$888.00	1 / lump sum	\$888.00	Y
PNC2120194B1-02-05	Custom Structures: Prototype Large Picnic Shelter	Supplier Product Code:	First Offer - \$103,958.40	1 / lump sum	\$103,958.40	Y
PNC2120194B1-02-06	Custom Structures: Upgrade of Shelter	Supplier Product Code:	First Offer - \$1,272.00	1 / lump sum	\$1,272.00	Y
PNC2120194B1-02-07	Custom Structures: Prototype Restroom with Janitor Closet	Supplier Product Code:	First Offer - \$239,046.00	1 / lump sum	\$239,046.00	Y
PNC2120194B1-02-08	Custom Structures: Prototype Restroom with Storage	Supplier Product Code:	First Offer - \$220,507.20	1 / lump sum	\$220,507.20	Y
PNC2120194B1-02-09	Custom Structures: Prototype Restroom with Office	Supplier Product Code:	First Offer - \$231,202.80	1 / lump sum	\$231,202.80	Y

Bid Allowance \$600,000.00

Lot Total **\$943,417.20**

Item #	Line Item	Notes	Unit Price	Qty/Unit	Attch. Docs
PNC2120194B1-03-01	Division 7: Aluminum Standing Seam Roof	Supplier Product Code:	First Offer - \$5.80	600 / square foot	\$3,480.00 Y

Bid Allowance \$600,000.00

Lot Total **\$3,480.00**

Item #	Line Item	Notes	Unit Price	Qty/Unit	Attch. Docs
PNC2120194B1-04-01	Division 10: Informational Kiosk	Supplier Product Code:	First Offer - \$14,370.36	2 / lump sum	\$28,740.72 Y
PNC2120194B1-04-02	Division 10: Informational Kiosk E- coating	Supplier Product Code:	First Offer - \$2,400.00	1 / lump sum	\$2,400.00 Y

Bid Allowance \$600,000.00

Lot Total **\$31,140.72**

Item #	Line Item	Notes	Unit Price	Qty/Unit		Attch. Docs
PNC2120194B1-05-01	Division 11: Playground A	Supplier Product Code:	First Offer - \$69,240.42	1 / lump sum	\$69,240.42	Y
PNC2120194B1-05-02	Division 11: Playground B	Supplier Product Code:	First Offer - \$106,732.25	1 / lump sum	\$106,732.25	Y
PNC2120194B1-05-03	Division 11: Playground C	Supplier Product Code:	First Offer - \$94,800.00	1 / lump sum	\$94,800.00	Y
PNC2120194B1-05-04	Division 11: Playground D	Supplier Product Code:	First Offer - \$98,408.48	1 / lump sum	\$98,408.48	Y
PNC2120194B1-05-05	Division 11: Playground E	Supplier Product Code:	First Offer - \$122,146.61	1 / lump sum	\$122,146.61	Y
PNC2120194B1-05-06	Division 11: Playground F	Supplier Product Code:	First Offer - \$110,400.00	1 / lump sum	\$110,400.00	Y
PNC2120194B1-05-07	Division 11: Playground G	Supplier Product Code:	First Offer - \$40,320.00	1 / lump sum	\$40,320.00	Y
PNC2120194B1-05-08	Division 11: Playground H	Supplier Product Code:	First Offer - \$54,696.10	1 / lump sum	\$54,696.10	Y
PNC2120194B1-05-09	Division 11: Playground I	Supplier Product Code:	First Offer - \$90,000.00	1 / lump sum	\$90,000.00	Y
PNC2120194B1-05-10	Division 11: Playground J	Supplier Product Code:	First Offer - \$95,110.78	1 / lump sum	\$95,110.78	Y
PNC2120194B1-05-11	Division 11: Play Components Price Group A	Supplier Product Code:	First Offer - \$1,800.00	3 / each	\$5,400.00	Y
PNC2120194B1-05-12	Division 11: Play Components Price Group B	Supplier Product Code:	First Offer - \$5,400.00	3 / each	\$16,200.00	Y

PNC2120194B1-05-13	Division 11: Play Components Price Group C	Supplier Product Code:	First Offer - \$9,600.00	1 / each	\$9,600.00	Y
PNC2120194B1-05-14	Division 11: Play Components Price Group D	Supplier Product Code:	First Offer - \$15,600.00	1 / each	\$15,600.00	Y

Bid Allowance \$600,000.00
Lot Total **\$928,654.64**

Item #	Line Item	Notes	Unit Price	Qty/Unit	Attch. Docs
--------	-----------	-------	------------	----------	-------------

PNC2120194B1-06-01	Division 13: Square Prefab Shelter	Supplier Product Code:	First Offer - \$38,002.80	1 / lump sum	\$38,002.80	Y
PNC2120194B1-06-02	Division 13: Hexagonal Prefab Shelter	Supplier Product Code:	First Offer - \$36,578.40	2 / lump sum	\$73,156.80	Y
PNC2120194B1-06-03	Division 13: Additional E-coating	Supplier Product Code: Supplier Notes: Not available from manufacture.	First Offer - \$0.01	3 / lump sum	\$0.03	Y
PNC2120194B1-06-04	Division 13: Square Prefab Shelter	Supplier Product Code:	First Offer - \$45,643.20	1 / lump sum	\$45,643.20	Y
PNC2120194B1-06-05	Division 13: Additional E-coating	Supplier Product Code: Supplier Notes: Not available from manufacture.	First Offer - \$0.01	1 / lump sum	\$0.01	Y

PNC2120194B1-06-06	Division 13: Hexagonal Prefab Shelter	Supplier Product Code:	First Offer - \$56,324.40	1 / lump sum	\$56,324.40	Y
--------------------	---	-------------------------------	----------------------------------	--------------	--------------------	----------

PNC2120194B1-06-07	Division 13: Additional E-coating	Supplier Product Code:	First Offer - \$0.01	1 / lump sum	\$0.01	Y
		Supplier Notes: Not available from manufacture.				

PNC2120194B1-06-08	Division 13: Prefab Shelter Upgrade	Supplier Product Code:	First Offer - \$1,200.00	6 / each	\$7,200.00	Y
--------------------	--	-------------------------------	---------------------------------	----------	-------------------	----------

PNC2120194B1-06-09	Division 13: Prefab Shelter Upgrade	Supplier Product Code:	First Offer - \$900.00	6 / each	\$5,400.00	Y
--------------------	--	-------------------------------	-------------------------------	----------	-------------------	----------

PNC2120194B1-06-10	Division 13: Shade Structure	Supplier Product Code:	First Offer - \$14,400.00	1 / lump sum	\$14,400.00	Y
--------------------	---------------------------------	-------------------------------	----------------------------------	--------------	--------------------	----------

PNC2120194B1-06-11	Division 13: Shade Structure	Supplier Product Code:	First Offer - \$18,996.00	1 / lump sum	\$18,996.00	Y
--------------------	---------------------------------	-------------------------------	----------------------------------	--------------	--------------------	----------

PNC2120194B1-06-12	Division 13: Shade Structure	Supplier Product Code:	First Offer - \$22,698.00	1 / lump sum	\$22,698.00	Y
--------------------	---------------------------------	-------------------------------	----------------------------------	--------------	--------------------	----------

PNC2120194B1-06-13	Division 13: Shade Structure	Supplier Product Code:	First Offer - \$27,860.40	2 / lump sum	\$55,720.80	Y
--------------------	---------------------------------	-------------------------------	----------------------------------	--------------	--------------------	----------

PNC2120194B1-06-14	Division 13: Shade Structure	Supplier Product Code:	First Offer - \$28,240.80	2 / lump sum	\$56,481.60	Y
--------------------	---------------------------------	-------------------------------	----------------------------------	--------------	--------------------	----------

Bid Allowance \$600,000.00

Lot Total **\$394,023.65**

Item #	Line Item	Notes	Unit Price	Qty/Unit	Attch. Docs
--------	-----------	-------	------------	----------	-------------

PNC2120194B1-07-01	Division 22:	Supplier	First Offer - \$8,795.34	2 / lump sum	\$17,590.68	Y
--------------------	--------------	-----------------	---------------------------------	--------------	--------------------	----------

Freestanding water cooler with bottle filler
Product Code:

PNC2120194B1-07-02	Division 22: Freestanding drinking fountain	Supplier Product Code:	First Offer - \$7,777.38	1 / lump sum	\$7,777.38	Y
--------------------	--	-------------------------------	---------------------------------	--------------	-------------------	---

Bid Allowance

\$600,000.00

Lot Total **\$25,368.06**

Item #	Line Item	Notes	Unit Price	Qty/Unit	Attch. Docs
PNC2120194B1-08-01	Division 26: Solar Powered Area Luminaire, 4500K	Supplier Product Code:	First Offer - \$3,954.00	10 / each	\$39,540.00 Y
PNC2120194B1-08-02	Division 26: Solar Powered Area Luminaire, 4500K	Supplier Product Code:	First Offer - \$3,954.00	10 / each	\$39,540.00 Y
PNC2120194B1-08-03	Division 26: Matching Pole for Solar Powered Area Luminaire	Supplier Product Code:	First Offer - \$2,490.66	10 / each	\$24,906.60 Y
PNC2120194B1-08-04	Division 26: Solar Powered Luminaire with Pole	Supplier Product Code:	First Offer - \$7,130.78	10 / each	\$71,307.80 Y
PNC2120194B1-08-05	Division 26: LED Bollard	Supplier Product Code:	First Offer - \$1,259.46	10 / each	\$12,594.60 Y
PNC2120194B1-08-06	Division 26: LED Area Luminaire	Supplier Product Code:	First Offer - \$730.45	10 / each	\$7,304.50 Y
PNC2120194B1-08-07	Division 26: LED Area Luminaire 5000K	Supplier Product Code:	First Offer - \$855.00	10 / each	\$8,550.00 Y
PNC2120194B1-08-08	Division 26: LED Area Luminaire 5000K	Supplier Product Code:	First Offer - \$983.40	10 / each	\$9,834.00 Y
PNC2120194B1-08-09	Division 26: LED Area Luminaire 5000K	Supplier Product Code:	First Offer - \$855.00	10 / each	\$8,550.00 Y
PNC2120194B1-08-10	Division 26: LED Area Luminaire 4000K	Supplier Product Code:	First Offer - \$745.86	10 / each	\$7,458.60 Y

PNC2120194B1-08-11	Division 26: LED Flood Light 5700K	Supplier Product Code:	First Offer - \$503.22	5 / each	\$2,516.10	Y
PNC2120194B1-08-12	Division 26: FWC certified LED Street Light	Supplier Product Code:	First Offer - \$2,395.80	10 / each	\$23,958.00	Y
PNC2120194B1-08-13	Division 26: Round Concrete Pole Standard	Supplier Product Code:	First Offer - \$3,067.68	10 / each	\$30,676.80	Y
PNC2120194B1-08-14	Division 26: Round Concrete or Composite Pole Standard	Supplier Product Code:	First Offer - \$2,387.16	10 / each	\$23,871.60	Y
PNC2120194B1-08-15	Division 26: Round Concrete or Composite Pole Standard	Supplier Product Code:	First Offer - \$2,541.24	10 / each	\$25,412.40	Y
PNC2120194B1-08-16	Division 26: Round Concrete or Composite Pole Standard	Supplier Product Code:	First Offer - \$2,765.94	5 / each	\$13,829.70	Y
PNC2120194B1-08-17	Division 26: Ameron Washington Pole	Supplier Product Code:	First Offer - \$4,897.38	5 / each	\$24,486.90	Y
PNC2120194B1-08-18	Division 26: Precast Concrete Pole	Supplier Product Code:	First Offer - \$1,847.88	10 / each	\$18,478.80	Y
PNC2120194B1-08-19	Division 26: Precast Concrete Pole	Supplier Product Code:	First Offer - \$2,077.68	10 / each	\$20,776.80	Y
PNC2120194B1-08-20	Division 26: Precast Concrete Pole	Supplier Product Code:	First Offer - \$2,199.66	10 / each	\$21,996.60	Y
PNC2120194B1-08-21	Division 26: Meter Can	Supplier Product Code:	First Offer - \$647.94	2 / each	\$1,295.88	Y
PNC2120194B1-08-22	Division 26: Meter Can	Supplier Product Code:	First Offer - \$1,458.00	2 / each	\$2,916.00	Y

PNC2120194B1--08-23	Division 26: Disconnect Switch	Supplier Product Code:	First Offer - \$2,582.40	2 / each	\$5,164.80	Y
PNC2120194B1--08-24	Division 26: Disconnect Switch	Supplier Product Code:	First Offer - \$4,054.80	2 / each	\$8,109.60	Y
PNC2120194B1--08-25	Division 26: Disconnect Switch	Supplier Product Code:	First Offer - \$5,606.40	2 / each	\$11,212.80	Y
PNC2120194B1--08-26	Division 26: Panel Board	Supplier Product Code:	First Offer - \$3,582.00	2 / each	\$7,164.00	Y
PNC2120194B1--08-27	Division 26: Panel Board	Supplier Product Code:	First Offer - \$3,582.00	2 / each	\$7,164.00	Y
PNC2120194B1--08-28	Division 26: Panel Board	Supplier Product Code:	First Offer - \$3,511.20	2 / each	\$7,022.40	Y
PNC2120194B1--08-29	Division 26: Panel Board	Supplier Product Code:	First Offer - \$4,026.00	2 / each	\$8,052.00	Y
PNC2120194B1--08-30	Division 26: Grounding Electrode	Supplier Product Code:	First Offer - \$138.28	20 / each	\$2,765.60	Y
PNC2120194B1--08-31	Division 26: Pull and Junction Boxes	Supplier Product Code:	First Offer - \$574.80	50 / each	\$28,740.00	Y
PNC2120194B1--08-32	Division 26: Circuit Breaker	Supplier Product Code:	First Offer - \$99.60	10 / each	\$996.00	Y
PNC2120194B1--08-33	Division 26: Circuit Breaker	Supplier Product Code:	First Offer - \$178.80	10 / each	\$1,788.00	Y
PNC2120194B1--08-34	Division 26: Circuit Breaker	Supplier Product Code:	First Offer - \$252.25	10 / each	\$2,522.50	Y
PNC2120194B1--08-35	Division 26: Circuit	Supplier	First Offer - \$343.73	10 / each	\$3,437.30	Y

Breaker	Product Code:	Supplier Product Code:	First Offer -			
PNC2120194B1-08-36	Division 26: Circuit Breaker		\$343.73	10 / each	\$3,437.30	Y
PNC2120194B1-08-37	Division 26: Circuit Breaker		\$343.73	10 / each	\$3,437.30	Y
PNC2120194B1-08-38	Division 26: Circuit Breaker		\$417.88	7 / each	\$2,925.16	Y
PNC2120194B1-08-39	Division 26: Electrical service feeder		\$4.62	300 / linear foot	\$1,386.00	Y
PNC2120194B1-08-40	Division 26: Electrical service feeder		\$5.62	300 / linear foot	\$1,686.00	Y
PNC2120194B1-08-41	Division 26: Electrical service feeder		\$7.14	300 / linear foot	\$2,142.00	Y
PNC2120194B1-08-42	Division 26: Electrical service feeder		\$8.90	300 / linear foot	\$2,670.00	Y
PNC2120194B1-08-43	Division 26: Electrical service feeder		\$13.79	300 / linear foot	\$4,137.00	Y
PNC2120194B1-08-44	Division 26: Electrical service feeder		\$16.86	300 / linear foot	\$5,058.00	Y
PNC2120194B1-08-45	Division 26: Electrical service feeder		\$24.18	300 / linear foot	\$7,254.00	Y
PNC2120194B1-08-46	Division 26: Electrical service feeder		\$29.80	300 / linear foot	\$8,940.00	Y
PNC2120194B1-08-47	Division 26: Electrical service feeder		\$73.91	300 / linear foot	\$22,173.00	Y

PNC2120194B1-08-48	Division 26: PVC Conduit	Supplier Product Code:	First Offer - \$9.77	300 / linear foot	\$2,931.00	Y
PNC2120194B1-08-49	Division 26: PVC Conduit	Supplier Product Code:	First Offer - \$20.02	300 / linear foot	\$6,006.00	Y
PNC2120194B1-08-50	Division 26: PVC Conduit	Supplier Product Code:	First Offer - \$10.07	300 / linear foot	\$3,021.00	Y
PNC2120194B1-08-51	Division 26: PVC Conduit	Supplier Product Code:	First Offer - \$13.04	300 / linear foot	\$3,912.00	Y
PNC2120194B1-08-52	Division 26: PVC Conduit	Supplier Product Code:	First Offer - \$21.79	300 / linear foot	\$6,537.00	Y
PNC2120194B1-08-53	Division 26: GRC Conduit	Supplier Product Code:	First Offer - \$6.89	300 / linear foot	\$2,067.00	Y
PNC2120194B1-08-54	Division 26: GRC Conduit	Supplier Product Code:	First Offer - \$10.69	100 / linear foot	\$1,069.00	Y
PNC2120194B1-08-55	Division 26: GRC Conduit	Supplier Product Code:	First Offer - \$22.10	100 / linear foot	\$2,210.00	Y
PNC2120194B1-08-56	Division 26: GRC Conduit	Supplier Product Code:	First Offer - \$51.14	100 / linear foot	\$5,114.00	Y

Bid Allowance

\$600,000.00

Lot Total **\$632,053.44**

Item #	Line Item	Notes	Unit Price	Qty/Unit	Attch. Docs
PNC2120194B1-09-01	Divisions 26 and 32: Irrigation Signal Wire	Supplier Product Code:	First Offer - \$0.38	1000 / linear foot	\$380.00 Y
PNC2120194B1-09-02	Divisions 26 and 32: Irrigation Common Wire	Supplier Product Code:	First Offer - \$0.58	1000 / linear foot	\$580.00 Y

PNC2120194B1-09-03	Divisions 26 and 32: Irrigation Wire Splice Box	Supplier Product Code:	First Offer - \$3.84	25 / linear foot	\$96.00	Y
PNC2120194B1-09-04	Divisions 26 and 32: Irrigation Power Wire	Supplier Product Code:	First Offer - \$3.84	1000 / linear foot	\$3,840.00	Y
PNC2120194B1-09-05	Divisions 26 and 32: Irrigation Power Wire	Supplier Product Code:	First Offer - \$6.30	1000 / linear foot	\$6,300.00	Y
PNC2120194B1-09-06	Divisions 26 and 32: Irrigation Power Wire	Supplier Product Code:	First Offer - \$6.90	1000 / linear foot	\$6,900.00	Y
PNC2120194B1-09-07	Divisions 26 and 32: Irrigation Power Wire	Supplier Product Code:	First Offer - \$7.80	1000 / linear foot	\$7,800.00	Y
PNC2120194B1-09-08	Divisions 26 and 32: Irrigation Wire Splice	Supplier Product Code:	First Offer - \$15.60	10 / each	\$156.00	Y
PNC2120194B1-09-09	Divisions 26 and 32: Irrigation Pump Station Disconnect	Supplier Product Code:	First Offer - \$1,420.96	2 / each	\$2,841.92	Y
PNC2120194B1-09-10	Divisions 26 and 32: Irrigation Pump Station Disconnect	Supplier Product Code:	First Offer - \$1,420.96	2 / each	\$2,841.92	Y
PNC2120194B1-09-11	Divisions 26 and 32: Irrigation Pump Station Disconnect	Supplier Product Code:	First Offer - \$1,493.48	2 / each	\$2,986.96	Y
PNC2120194B1-09-12	Divisions 26 and 32: Irrigation Pump Station Disconnect	Supplier Product Code:	First Offer - \$1,493.48	2 / each	\$2,986.96	Y

Bid Allowance

\$600,000.00

Lot Total **\$37,709.76**

Item #	Line Item	Notes	Unit Price	Qty/Unit	Attch. Docs	
PNC2120194B1-10-01	Division 31: Tree Removal	Supplier Product Code:	First Offer - \$720.00	10 / each	\$7,200.00	Y
PNC2120194B1-10-02	Division 31: Tree Removal	Supplier Product	First Offer - \$1,440.00	10 / each	\$14,400.00	Y

Code:

PNC2120194B1-10-03	Division 31: Tree Removal	Supplier Product Code:	First Offer - \$2,160.00	10 / each	\$21,600.00	Y
PNC2120194B1-10-04	Division 31: Manual Removal of Exotics Crew	Supplier Product Code:	First Offer - \$96.00	50 / hour	\$4,800.00	Y
PNC2120194B1-10-05	Division 31: Foliar Removal of Exotics Crew	Supplier Product Code:	First Offer - \$84.00	25 / hour	\$2,100.00	Y
PNC2120194B1-10-06	Division 31: Stump Treatment	Supplier Product Code:	First Offer - \$3,600.00	2 / acre	\$7,200.00	Y
PNC2120194B1-10-07	Division 31: Basal Bark Removal of Exotics	Supplier Product Code:	First Offer - \$3,000.00	2 / acre	\$6,000.00	Y
PNC2120194B1-10-08	Division 31: Removal of Exotics, Frill and Girdle	Supplier Product Code:	First Offer - \$120.00	25 / hour	\$3,000.00	Y
PNC2120194B1-10-09	Division 31: Chipping with recycling	Supplier Product Code:	First Offer - \$192.00	25 / hour	\$4,800.00	Y
PNC2120194B1-10-10	Division 31: Chipping for stockpiling	Supplier Product Code:	First Offer - \$192.00	25 / hour	\$4,800.00	Y

Bid Allowance

\$600,000.00

Lot Total **\$75,900.00**

Item #	Line Item	Notes	Unit Price	Qty/Unit		Attch. Docs
PNC2120194B1-11-01	Division 32: Color-coated Chain Link Fence	Supplier Product Code:	First Offer - \$31.20	1000 / linear foot	\$31,200.00	Y
PNC2120194B1-11-02	Division 32: Color-coated Chain Link Fence	Supplier Product Code:	First Offer - \$36.00	1000 / linear foot	\$36,000.00	Y
PNC2120194B1-11-03	Division 32: Color-coated	Supplier Product Code:	First Offer - \$48.00	1000 / linear foot	\$48,000.00	Y

	Chain Link Fence	Code:				
PNC2120194B1-11-04	Division 32: Grounding of Chain Link Fencing	Supplier Product Code:	First Offer - \$1,500.00	10 / each	\$15,000.00	Y
PNC2120194B1-11-05	Division 32: Bottom Rail for Chain Link Fence	Supplier Product Code:	First Offer - \$4.80	1000 / linear foot	\$4,800.00	Y
PNC2120194B1-11-06	Division 32: Remove and Dispose of Fencing	Supplier Product Code:	First Offer - \$3.90	1000 / linear foot	\$3,900.00	Y
PNC2120194B1-11-07	Division 32: Remove and Dispose of Fencing	Supplier Product Code:	First Offer - \$5.40	200 / linear foot	\$1,080.00	Y
PNC2120194B1-11-08	Division 32: Additional Line Post with Caps	Supplier Product Code:	First Offer - \$72.00	50 / each	\$3,600.00	Y
PNC2120194B1-11-09	Division 32: Corner Post with Complete Double Brace	Supplier Product Code:	First Offer - \$174.00	50 / each	\$8,700.00	Y
PNC2120194B1-11-10	Division 32: Additional Line Post with Caps	Supplier Product Code:	First Offer - \$96.00	2 / each	\$192.00	Y
PNC2120194B1-11-11	Division 32: Corner Post with Double Brace Assembly	Supplier Product Code:	First Offer - \$186.00	4 / each	\$744.00	Y
PNC2120194B1-11-12	Division 32: Single Gate, 4 x 6 ft.	Supplier Product Code:	First Offer - \$420.00	10 / each	\$4,200.00	Y
PNC2120194B1-11-13	Division 32: Double Gate, 6 to 8 ft.	Supplier Product Code:	First Offer - \$792.00	6 / each	\$4,752.00	Y
PNC2120194B1-11-14	Division 32: Double Gate, 12	Supplier Product Code:	First Offer - \$1,572.00	4 / each	\$6,288.00	Y

to 16 ft. **Code:**

PNC2120194B1-11-15	Division 32: Double Gate, 20 to 24 ft.	Supplier Product Code:	First Offer - \$2,364.00	1 / each	\$2,364.00	Y
PNC2120194B1-11-16	Division 32: Single Gate, 4 x 8 ft.	Supplier Product Code:	First Offer - \$432.00	3 / each	\$1,296.00	Y
PNC2120194B1-11-17	Division 32: Double Gate, 8 x 8 ft.	Supplier Product Code:	First Offer - \$858.00	1 / each	\$858.00	Y
PNC2120194B1-11-18	Division 32: Double Gate, 12 to 16 ft.	Supplier Product Code:	First Offer - \$1,716.00	4 / each	\$6,864.00	Y
PNC2120194B1-11-19	Division 32: Double Gate, 20 to 24 ft.	Supplier Product Code:	First Offer - \$2,568.00	2 / each	\$5,136.00	Y
PNC2120194B1-11-20	Division 32: Cantilevered Sliding Double Gate	Supplier Product Code:	First Offer - \$3,540.00	1 / each	\$3,540.00	Y
PNC2120194B1-11-21	Division 32: Cantilevered Sliding Double Gate	Supplier Product Code:	First Offer - \$3,852.00	1 / each	\$3,852.00	Y
PNC2120194B1-11-22	Division 32: Cantilevered Sliding Double Gate	Supplier Product Code:	First Offer - \$4,164.00	1 / each	\$4,164.00	Y
PNC2120194B1-11-23	Division 32: Cantilevered Sliding Double Gate	Supplier Product Code:	First Offer - \$5,904.00	1 / each	\$5,904.00	Y
PNC2120194B1-11-24	Division 32: Cantilevered Sliding Double Gate	Supplier Product Code:	First Offer - \$6,408.00	1 / each	\$6,408.00	Y
PNC2120194B1-11-25	Division 32: Cantilevered Sliding Double Gate	Supplier Product Code:	First Offer - \$6,936.00	1 / each	\$6,936.00	Y

PNC2120194B1-11-26	Division 32: Temporary Fence	Supplier Product Code:	First Offer - \$3.00	3000 / linear foot	\$9,000.00	Y
PNC2120194B1-11-27	Division 32: Steel Picket Fence	Supplier Product Code:	First Offer - \$90.00	400 / linear foot	\$36,000.00	Y
PNC2120194B1-11-28	Division 32: Steel Picket Fence Single Swing Gate	Supplier Product Code:	First Offer - \$1,440.00	4 / each	\$5,760.00	Y
PNC2120194B1-11-29	Division 32: Steel Picket Fence Double Swing Gate	Supplier Product Code:	First Offer - \$2,520.00	4 / each	\$10,080.00	Y
PNC2120194B1-11-30	Division 32: Cantilevered Steel Picket Sliding Gate	Supplier Product Code:	First Offer - \$5,400.00	2 / each	\$10,800.00	Y
PNC2120194B1-11-31	Division 32: Masonry Column	Supplier Product Code:	First Offer - \$762.53	10 / each	\$7,625.30	Y
PNC2120194B1-11-32	Division 32: Recycled Plastic Double Rail Fence	Supplier Product Code:	First Offer - \$78.00	100 / linear foot	\$7,800.00	Y
PNC2120194B1-11-33	Division 32: HDPE Four Rail Equine Fence	Supplier Product Code:	First Offer - \$48.92	500 / linear foot	\$24,460.00	Y
PNC2120194B1-11-34	Division 32: Tree Relocation 21 to 30 ft.	Supplier Product Code:	First Offer - \$3,600.00	3 / each	\$10,800.00	Y
PNC2120194B1-11-35	Division 32: Tree Removal greater than 30 ft.	Supplier Product Code:	First Offer - \$6,000.00	2 / each	\$12,000.00	Y
PNC2120194B1-11-36	Division 32: Palm Relocation less than 15 ft.	Supplier Product Code:	First Offer - \$840.00	3 / each	\$2,520.00	Y
PNC2120194B1-11-37	Division 32:	Supplier	First Offer - \$1,020.00	3 / each	\$3,060.00	Y

	Palm Relocation 15 to 25 ft.	Product Code:				
PNC2120194B1-11-38	Division 32: Palm Relocation 25 to 35 ft.	Supplier Product Code:	First Offer - \$1,200.00	3 / each	\$3,600.00	Y
PNC2120194B1-11-39	Division 32: Palm Relocation greater than 35 ft.	Supplier Product Code:	First Offer - \$1,440.00	2 / each	\$2,880.00	Y
PNC2120194B1-11-40	Division 32: Landscaping Trees Price Group A	Supplier Product Code:	First Offer - \$38.40	350 / linear foot	\$13,440.00	Y
PNC2120194B1-11-41	Division 32: Landscaping Trees Price Group B	Supplier Product Code:	First Offer - \$61.20	350 / linear foot	\$21,420.00	Y
PNC2120194B1-11-42	Division 32: Landscaping Trees Price Group C	Supplier Product Code:	First Offer - \$49.20	350 / linear foot	\$17,220.00	Y
PNC2120194B1-11-43	Division 32: Landscaping Trees Price Group D	Supplier Product Code:	First Offer - \$67.20	350 / linear foot	\$23,520.00	Y
PNC2120194B1-11-44	Division 32: Landscaping Trees Price Group E	Supplier Product Code:	First Offer - \$72.00	350 / linear foot	\$25,200.00	Y
PNC2120194B1-11-45	Division 32: Container Trees and Palms Price Group A	Supplier Product Code:	First Offer - \$60.00	6 / each	\$360.00	Y
PNC2120194B1-11-46	Division 32: Container Trees and Palms Price Group B	Supplier Product Code:	First Offer - \$60.00	6 / each	\$360.00	Y
PNC2120194B1-11-47	Division 32: Container Trees and Palms Price Group C	Supplier Product Code:	First Offer - \$84.00	6 / each	\$504.00	Y

PNC2120194B1-11-48	Division 32: Container Trees and Palms Price Group D	Supplier Product Code:	First Offer - \$120.00	6 / each	\$720.00	Y
PNC2120194B1-11-49	Division 32: Shrubs Price Group A	Supplier Product Code:	First Offer - \$14.40	150 / each	\$2,160.00	Y
PNC2120194B1-11-50	Division 32: Shrubs Price Group B	Supplier Product Code:	First Offer - \$19.20	150 / each	\$2,880.00	Y
PNC2120194B1-11-51	Division 32: Shrubs Price Group C	Supplier Product Code:	First Offer - \$42.00	150 / each	\$6,300.00	Y
PNC2120194B1-11-52	Division 32: Provide Argentine Bahia	Supplier Product Code:	First Offer - \$0.54	4000 / square foot	\$2,160.00	Y
PNC2120194B1-11-53	Division 32: Provide Pensacola Bahia	Supplier Product Code:	First Offer - \$0.54	2000 / square foot	\$1,080.00	Y
PNC2120194B1-11-54	Division 32: Provide St. Augustine Sod	Supplier Product Code:	First Offer - \$0.66	2000 / square foot	\$1,320.00	Y
PNC2120194B1-11-55	Division 32: Provide Floritam Sod	Supplier Product Code:	First Offer - \$0.66	2000 / square foot	\$1,320.00	Y
PNC2120194B1-11-56	Division 32: Provide Bermuda Grass Topsoil	Supplier Product Code:	First Offer - \$48.00	50 / cubic yard	\$2,400.00	Y
PNC2120194B1-11-57	Division 32: Provide Rolled Tifway 419 Bermuda Grass	Supplier Product Code:	First Offer - \$0.78	3500 / square foot	\$2,730.00	Y
PNC2120194B1-11-58	Division 32: Provide Tifway 419 Bermuda Grass	Supplier Product Code:	First Offer - \$600.00	10 / each	\$6,000.00	Y
PNC2120194B1-11-59	Division 32: Provide Seeding	Supplier Product Code:	First Offer - \$2.40	2000 / square yard	\$4,800.00	Y

Code:

PNC2120194B1--11-60	Division 32: Fertilizer, Herbicides or Insecticides application	Supplier Product Code:	First Offer - \$120.00	50 / hour	\$6,000.00	Y
PNC2120194B1--11-61	Division 32: Additional Watering after Final Completion	Supplier Product Code:	First Offer - \$0.55	1500 / kilogallon	\$825.00	Y
PNC2120194B1--11-62	Division 32: Synthetic Grass Surfacing system	Supplier Product Code:	First Offer - \$18.95	4000 / square foot	\$75,800.00	Y
PNC2120194B1--11-63	Division 32: Synthetic Grass Surfacing system	Supplier Product Code:	First Offer - \$21.26	1150 / square foot	\$24,449.00	Y
PNC2120194B1--11-64	Division 32: Synthetic Grass Surfacing system	Supplier Product Code:	First Offer - \$22.97	1000 / square foot	\$22,970.00	Y
PNC2120194B1--11-65	Division 32: SBR Bonded Mulch surface system	Supplier Product Code:	First Offer - \$17.65	2000 / square foot	\$35,300.00	Y
PNC2120194B1--11-66	Division 32: SBR Bonded Mulch surface system	Supplier Product Code:	First Offer - \$17.32	3000 / square foot	\$51,960.00	Y
PNC2120194B1--11-67	Division 32: EPDM surface system	Supplier Product Code:	First Offer - \$15.36	2000 / square foot	\$30,720.00	Y
PNC2120194B1--11-68	Division 32: EPDM surface system	Supplier Product Code:	First Offer - \$15.49	3000 / square foot	\$46,470.00	Y
PNC2120194B1--11-69	Division 32: EPDM surface system	Supplier Product Code:	First Offer - \$18.38	1150 / square foot	\$21,137.00	Y
PNC2120194B1--11-70	Division 32: Synthetic Tennis	Supplier Product Code:	First Offer - \$1.20	2810 / square foot	\$3,372.00	Y

Court Surfacing Code:
System

PNC2120194B1-11-71	Division 32: Lateral Pipe	Supplier Product Code:	First Offer - \$2.76	500 / linear foot	\$1,380.00	Y
PNC2120194B1-11-72	Division 32: Lateral Pipe	Supplier Product Code:	First Offer - \$3.60	500 / linear foot	\$1,800.00	Y
PNC2120194B1-11-73	Division 32: Lateral Pipe	Supplier Product Code:	First Offer - \$6.30	500 / linear foot	\$3,150.00	Y
PNC2120194B1-11-74	Division 32: Lateral Pipe	Supplier Product Code:	First Offer - \$7.80	500 / linear foot	\$3,900.00	Y
PNC2120194B1-11-75	Division 32: Lateral Pipe	Supplier Product Code:	First Offer - \$6.00	500 / linear foot	\$3,000.00	Y
PNC2120194B1-11-76	Division 32: Lateral Pipe	Supplier Product Code:	First Offer - \$7.80	500 / linear foot	\$3,900.00	Y
PNC2120194B1-11-77	Division 32: Main Line Pipe	Supplier Product Code:	First Offer - \$12.00	500 / linear foot	\$6,000.00	Y
PNC2120194B1-11-78	Division 32: Main Line Pipe	Supplier Product Code:	First Offer - \$21.60	500 / linear foot	\$10,800.00	Y
PNC2120194B1-11-79	Division 32: Main Line Pipe	Supplier Product Code:	First Offer - \$54.00	500 / linear foot	\$27,000.00	Y
PNC2120194B1-11-80	Division 32: Thrust Block	Supplier Product Code:	First Offer - \$60.00	20 / each	\$1,200.00	Y
PNC2120194B1-11-81	Division 32: Electrical Wire Sleeving	Supplier Product Code:	First Offer - \$3.60	20 / linear foot	\$72.00	Y
PNC2120194B1-11-82	Division 32: Pipe Sleeving	Supplier Product Code:	First Offer - \$2.11	20 / linear foot	\$42.20	Y

PNC2120194B1--11-83	Division 32: Pipe Sleaving	Supplier Product Code:	First Offer - \$12.00	20 / linear foot	\$240.00	Y
PNC2120194B1--11-84	Division 32: Pipe Sleaving	Supplier Product Code:	First Offer - \$21.60	20 / linear foot	\$432.00	Y
PNC2120194B1--11-85	Division 32: Pipe Sleaving	Supplier Product Code:	First Offer - \$24.00	20 / linear foot	\$480.00	Y
PNC2120194B1--11-86	Division 32: Pipe Sleaving	Supplier Product Code:	First Offer - \$30.00	20 / linear foot	\$600.00	Y
PNC2120194B1--11-87	Division 32: Pipe Sleaving	Supplier Product Code:	First Offer - \$30.00	20 / linear foot	\$600.00	Y
PNC2120194B1--11-88	Division 32: Lake source suction line	Supplier Product Code:	First Offer - \$32.70	100 / linear foot	\$3,270.00	Y
PNC2120194B1--11-89	Division 32: Swing check valve	Supplier Product Code:	First Offer - \$945.60	5 / each	\$4,728.00	Y
PNC2120194B1--11-90	Division 32: Lake source suction line	Supplier Product Code:	First Offer - \$44.28	100 / linear foot	\$4,428.00	Y
PNC2120194B1--11-91	Division 32: Swing check valve	Supplier Product Code:	First Offer - \$1,098.00	5 / each	\$5,490.00	Y
PNC2120194B1--11-92	Division 32: Lake source suction line	Supplier Product Code:	First Offer - \$71.52	100 / linear foot	\$7,152.00	Y
PNC2120194B1--11-93	Division 32: Swing check valve	Supplier Product Code:	First Offer - \$1,544.28	5 / each	\$7,721.40	Y
PNC2120194B1--11-94	Division 32: Well source suction line	Supplier Product Code:	First Offer - \$83.16	100 / linear foot	\$8,316.00	Y
PNC2120194B1--11-95	Division 32:	Supplier	First Offer - \$1,022.76	5 / each	\$5,113.80	Y

	Swing Check suction line	Product Code:				
PNC2120194B1-11-96	Division 32: Well source suction line	Supplier Product Code:	First Offer - \$95.64	100 / linear foot	\$9,564.00	Y
PNC2120194B1-11-97	Division 32: Swing check suction line	Supplier Product Code:	First Offer - \$1,298.28	5 / each	\$6,491.40	Y
PNC2120194B1-11-98	Division 32: Well source suction line	Supplier Product Code:	First Offer - \$213.96	100 / linear foot	\$21,396.00	Y
PNC2120194B1-11-99	Division 32: Swing check suction line	Supplier Product Code:	First Offer - \$1,157.16	5 / each	\$5,785.80	Y
PNC2120194B1-11-100	Division 32: Well Drilling and Casing	Supplier Product Code:	First Offer - \$102.00	100 / linear foot	\$10,200.00	Y
PNC2120194B1-11-101	Division 32: Centrifugal Pump System	Supplier Product Code:	First Offer - \$19,708.02	2 / each	\$39,416.04	Y
PNC2120194B1-11-102	Division 32: Centrifugal Pump System	Supplier Product Code:	First Offer - \$18,855.97	2 / each	\$37,711.94	Y
PNC2120194B1-11-103	Division 32: Centrifugal Pump System	Supplier Product Code:	First Offer - \$19,270.36	2 / each	\$38,540.72	Y
PNC2120194B1-11-104	Division 32: Centrifugal Pump System	Supplier Product Code:	First Offer - \$24,142.86	1 / each	\$24,142.86	Y
PNC2120194B1-11-105	Division 32: Centrifugal Pump System	Supplier Product Code:	First Offer - \$29,216.74	1 / each	\$29,216.74	Y
PNC2120194B1-11-106	Division 32: Centrifugal Pump System	Supplier Product Code:	First Offer - \$32,027.80	1 / each	\$32,027.80	Y
PNC2120194B1-11-107	Division 32: Lake Refill	Supplier Product Code:	First Offer - \$27,973.58	1 / each	\$27,973.58	Y

PNC2120194B1-11-108	Division 32: Calibrate Flow Meter	Supplier Product Code:	First Offer - \$512.16	1 / each	\$512.16	Y
PNC2120194B1-11-109	Division 32: Flow Meter	Supplier Product Code:	First Offer - \$2,118.48	1 / each	\$2,118.48	Y
PNC2120194B1-11-110	Division 32: Flow Meter	Supplier Product Code:	First Offer - \$3,509.46	1 / each	\$3,509.46	Y
PNC2120194B1-11-111	Division 32: Intake Screen	Supplier Product Code:	First Offer - \$9,068.72	1 / each	\$9,068.72	Y
PNC2120194B1-11-112	Division 32: Intake Screen	Supplier Product Code:	First Offer - \$10,256.00	1 / each	\$10,256.00	Y
PNC2120194B1-11-113	Division 32: Irrigation Controller	Supplier Product Code:	First Offer - \$460.80	1 / each	\$460.80	Y
PNC2120194B1-11-114	Division 32: Pump System Controller	Supplier Product Code:	First Offer - \$16,740.65	1 / each	\$16,740.65	Y
PNC2120194B1-11-115	Division 32: Pump System Controller	Supplier Product Code:	First Offer - \$21,967.01	1 / each	\$21,967.01	Y
PNC2120194B1-11-116	Division 32: Lake source suction line	Supplier Product Code:	First Offer - \$98.64	100 / linear foot	\$9,864.00	Y
PNC2120194B1-11-117	Division 32: Swing Check Valve	Supplier Product Code:	First Offer - \$2,241.86	1 / each	\$2,241.86	Y
PNC2120194B1-11-118	Division 32: Pump system discharge	Supplier Product Code:	First Offer - \$655.33	1 / each	\$655.33	Y
PNC2120194B1-11-119	Division 32: Pump system discharge	Supplier Product Code:	First Offer - \$946.33	1 / each	\$946.33	Y
PNC2120194B1-11-120	Division 32:	Supplier	First Offer - \$1,778.59	1 / each	\$1,778.59	Y

Pump system
discharge **Product
Code:**

Bid Allowance

\$600,000.00

Lot Total **\$1,290,461.97**

Item #	Line Item	Notes	Unit Price	Qty/Unit	Attch. Docs
PNC2120194B1-12-01	FDOT/Division 32: Work Zone Sign	Supplier Product Code:	First Offer - \$0.78	10 / day	\$7.80 Y
PNC2120194B1-12-02	FDOT/Division 32: Business Sign	Supplier Product Code:	First Offer - \$6.18	10 / day	\$61.80 Y
PNC2120194B1-12-03	FDOT/Division 32: Temporary Concrete Barrier Wall	Supplier Product Code:	First Offer - \$42.00	100 / linear foot	\$4,200.00 Y
PNC2120194B1-12-04	FDOT/Division 32: Temporary Concrete Barrier Wall	Supplier Product Code:	First Offer - \$90.00	5 / day	\$450.00 Y
PNC2120194B1-12-05	FDOT/Division 32: Removable Pavement Marking Tape	Supplier Product Code:	First Offer - \$5.70	150 / linear foot	\$855.00 Y
PNC2120194B1-12-06	FDOT/Division 32: Artificial Covering or Rolled Erosion Control	Supplier Product Code:	First Offer - \$0.50	50 / square yard	\$25.00 Y
PNC2120194B1-12-07	FDOT/Division 32: Sediment Barrier	Supplier Product Code:	First Offer - \$0.82	200 / linear foot	\$164.00 Y
PNC2120194B1-12-08	FDOT/Division 32: Floating Turbidity Barrier	Supplier Product Code:	First Offer - \$8.82	300 / linear foot	\$2,646.00 Y
PNC2120194B1-12-09	FDOT/Division 32: Staked Turbidity Barrier	Supplier Product Code:	First Offer - \$4.52	100 / linear foot	\$452.00 Y
PNC2120194B1-12-10	FDOT/Division 32: Inlet Protection System	Supplier Product Code:	First Offer - \$60.00	3 / each	\$180.00 Y

PNC2120194B1-12-11	FDOT/Division 32: Clearing and Grubbing	Supplier Product Code:	First Offer - \$1.80	150 / square yard	\$270.00	Y
PNC2120194B1-12-12	FDOT/Division 32: Remove Existing Pavement or Concrete	Supplier Product Code:	First Offer - \$9.60	3000 / square yard	\$28,800.00	Y
PNC2120194B1-12-13	FDOT/Division 32: Plugging Artesian Water Well	Supplier Product Code:	First Offer - \$2,800.00	1 / each	\$2,800.00	Y
PNC2120194B1-12-14	FDOT/Division 32: Regular Excavation	Supplier Product Code:	First Offer - \$7.80	200 / cubic yard	\$1,560.00	Y
PNC2120194B1-12-15	FDOT/Division 32: Channel Excavation	Supplier Product Code:	First Offer - \$24.00	200 / cubic yard	\$4,800.00	Y
PNC2120194B1-12-16	FDOT/Division 32: Embankment	Supplier Product Code:	First Offer - \$12.00	100 / cubic yard	\$1,200.00	Y
PNC2120194B1-12-17	FDOT/Division 32: Flowable Fill	Supplier Product Code:	First Offer - \$156.00	100 / cubic yard	\$15,600.00	Y
PNC2120194B1-12-18	FDOT/Division 32: Geosynthetic Reinforced Soil Slope	Supplier Product Code:	First Offer - \$8.40	30 / square foot	\$252.00	Y
PNC2120194B1-12-19	FDOT/Division 32: Subgrade Stabilization	Supplier Product Code:	First Offer - \$6.00	100 / square foot	\$600.00	Y
PNC2120194B1-12-20	FDOT/Division 32: Prepared Finished Soil Layer	Supplier Product Code:	First Offer - \$6.40	150 / square yard	\$960.00	Y
PNC2120194B1-12-21	FDOT/Division 32: Prepared Organic Soil Layer	Supplier Product Code:	First Offer - \$10.20	150 / square yard	\$1,530.00	Y
PNC2120194B1-12-22	FDOT/Division 32: Washed Rock	Supplier Product Code:	First Offer - \$27.53	1000 / ton	\$27,530.00	Y

PNC2120194B1-12-23	FDOT/Division 32: Optional Base Group	Supplier Product Code:	First Offer - \$23.17	50 / square yard	\$1,158.50	Y
PNC2120194B1-12-24	FDOT/Division 32: Optional Base Group	Supplier Product Code:	First Offer - \$32.47	50 / square yard	\$1,623.50	Y
PNC2120194B1-12-25	FDOT/Division 32: Milling Existing Asphalt Pavement	Supplier Product Code:	First Offer - \$4.00	1500 / square yard	\$6,000.00	Y
PNC2120194B1-12-26	FDOT/Division 32: Milling Existing Asphalt Pavement	Supplier Product Code:	First Offer - \$5.20	1500 / square yard	\$7,800.00	Y
PNC2120194B1-12-27	FDOT/Division 32: Milling Existing Asphalt Pavement	Supplier Product Code:	First Offer - \$6.40	1500 / square yard	\$9,600.00	Y
PNC2120194B1-12-28	FDOT/Division 32: Milling Existing Asphalt Pavement	Supplier Product Code:	First Offer - \$8.40	1500 / square yard	\$12,600.00	Y
PNC2120194B1-12-29	FDOT/Division 32: Superpave Asphaltic Concrete	Supplier Product Code:	First Offer - \$20.04	4500 / square yard	\$90,180.00	Y
PNC2120194B1-12-30	FDOT/Division 32: Superpave Asphaltic Concrete	Supplier Product Code:	First Offer - \$188.52	500 / ton	\$94,260.00	Y
PNC2120194B1-12-31	FDOT/Division 32: Class I Miscellaneous Concrete	Supplier Product Code:	First Offer - \$210.00	300 / cubic yard	\$63,000.00	Y
PNC2120194B1-12-32	FDOT/Division 32: Adjust Inlets	Supplier Product Code:	First Offer - \$1,080.00	2 / each	\$2,160.00	Y
PNC2120194B1-12-33	FDOT/Division 32: Adjust Maintenance Access Structure	Supplier Product Code:	First Offer - \$3,213.60	1 / each	\$3,213.60	Y
PNC2120194B1-12-34	FDOT/Division 32: Maintenance Hatch	Supplier Product Code:	First Offer - \$4,200.00	1 / each	\$4,200.00	Y
PNC2120194B1-12-35	FDOT/Division 32: Maintenance Hatch	Supplier Product Code:	First Offer - \$7,800.00	1 / each	\$7,800.00	Y

Code:

PNC2120194B1--12-36	FDOT/Division 32: Adjust Maintenance Hatch	Supplier Product Code:	First Offer - \$600.00	1 / each	\$600.00	Y
PNC2120194B1--12-37	FDOT/Division 32: Adjust Valve Boxes	Supplier Product Code:	First Offer - \$222.00	1 / each	\$222.00	Y
PNC2120194B1--12-38	FDOT/Division 32: Yard Drain	Supplier Product Code:	First Offer - \$1,920.00	1 / each	\$1,920.00	Y
PNC2120194B1--12-39	FDOT/Division 32: Modify Existing Drainage Structure	Supplier Product Code:	First Offer - \$1,800.00	1 / each	\$1,800.00	Y
PNC2120194B1--12-40	FDOT/Division 32: Concrete Curb and Gutter Type F	Supplier Product Code:	First Offer - \$26.40	300 / linear foot	\$7,920.00	Y
PNC2120194B1--12-41	FDOT/Division 32: Concrete Curb Type D	Supplier Product Code:	First Offer - \$21.60	300 / linear foot	\$6,480.00	Y
PNC2120194B1--12-42	FDOT/Division 32: Concrete Sidewalk	Supplier Product Code:	First Offer - \$54.00	2500 / square yard	\$135,000.00	Y
PNC2120194B1--12-43	FDOT/Division 32: Concrete Sidewalk	Supplier Product Code:	First Offer - \$61.20	500 / square yard	\$30,600.00	Y
PNC2120194B1--12-44	FDOT/Division 32: Patterned Pavement, Green Bike Lane	Supplier Product Code:	First Offer - \$156.00	100 / square yard	\$15,600.00	Y
PNC2120194B1--12-45	FDOT/Division 32: Install Architectural Pavers for Roadways	Supplier Product Code:	First Offer - \$6.60	25 / square foot	\$165.00	Y
PNC2120194B1--12-46	FDOT/Division 32: Install Architectural Pavers for Sidewalk	Supplier Product Code:	First Offer - \$6.24	25 / square foot	\$156.00	Y
PNC2120194B1--12-47	FDOT/Division 32: Reflective Pavement	Supplier Product Code:	First Offer - \$5.98	50 / each	\$299.00	Y

Marker, Class B	Code:	Supplier Product Code:	First Offer -			
PNC2120194B1--12-48	FDOT/Division 32: Removal of Pavement Marker	Supplier Product Code:	First Offer - \$1.80	50 / each	\$90.00	Y
PNC2120194B1--12-49	FDOT/Division 32: Removal of Painted Striping	Supplier Product Code:	First Offer - \$21.60	200 / linear foot	\$4,320.00	Y
PNC2120194B1--12-50	FDOT/Division 32: Painted Directional Arrows	Supplier Product Code:	First Offer - \$54.00	10 / each	\$540.00	Y
PNC2120194B1--12-51	FDOT/Division 32: Painted Traffic Stripe	Supplier Product Code:	First Offer - \$0.54	500 / linear foot	\$270.00	Y
PNC2120194B1--12-52	FDOT/Division 32: Painted Traffic Stripe	Supplier Product Code:	First Offer - \$0.48	500 / linear foot	\$240.00	Y
PNC2120194B1--12-53	FDOT/Division 32: Painted Traffic Stripe	Supplier Product Code:	First Offer - \$1.56	100 / linear foot	\$156.00	Y
PNC2120194B1--12-54	FDOT/Division 32: Painted Traffic Stripe	Supplier Product Code:	First Offer - \$3.60	100 / linear foot	\$360.00	Y
PNC2120194B1--12-55	FDOT/Division 32: Thermoplastic Traffic Stripe	Supplier Product Code:	First Offer - \$1.34	500 / linear foot	\$670.00	Y
PNC2120194B1--12-56	FDOT/Division 32: Thermoplastic Traffic Stripe	Supplier Product Code:	First Offer - \$1.32	500 / linear foot	\$660.00	Y
PNC2120194B1--12-57	FDOT/Division 32: Thermoplastic Traffic Stripe	Supplier Product Code:	First Offer - \$7.80	500 / linear foot	\$3,900.00	Y
PNC2120194B1--12-58	FDOT/Division 32: Removal of Thermoplastic Pavement Marker	Supplier Product Code:	First Offer - \$1.80	50 / each	\$90.00	Y
PNC2120194B1--12-59	FDOT/Division 32: Thermoplastic Solid Traffic Stripe	Supplier Product Code:	First Offer - \$1.98	50 / linear foot	\$99.00	Y

PNC2120194B1-12-60	FDOT/Division 32: Thermoplastic Solid Traffic Stripe	Supplier Product Code:	First Offer - \$2.64	100 / linear foot	\$264.00	Y
PNC2120194B1-12-61	FDOT/Division 32: Thermoplastic Traffic Stripe 18 in. Solid	Supplier Product Code:	First Offer - \$4.32	100 / linear foot	\$432.00	Y
PNC2120194B1-12-62	FDOT/Division 32: Thermoplastic Pavement Messages and Symbols	Supplier Product Code:	First Offer - \$270.00	10 / each	\$2,700.00	Y
PNC2120194B1-12-63	FDOT/Division 32: Thermoplastic Directional Arrow	Supplier Product Code:	First Offer - \$90.00	10 / each	\$900.00	Y
PNC2120194B1-12-64	FDOT/Division 32: Guide Lines	Supplier Product Code:	First Offer - \$1.38	200 / linear foot	\$276.00	Y
PNC2120194B1-12-65	FDOT/Division 32: Steel Guardrail	Supplier Product Code:	First Offer - \$55.13	200 / linear foot	\$11,026.00	Y
PNC2120194B1-12-66	FDOT/Division 32: Steel Guardrail, Shop Bent Panels	Supplier Product Code:	First Offer - \$71.28	100 / linear foot	\$7,128.00	Y
PNC2120194B1-12-67	FDOT/Division 32: End Anchorage Assembly Type II	Supplier Product Code:	First Offer - \$1,576.08	4 / each	\$6,304.32	Y
PNC2120194B1-12-68	FDOT/Division 32: Guardrail Removal	Supplier Product Code:	First Offer - \$27.72	100 / linear foot	\$2,772.00	Y
PNC2120194B1-12-69	FDOT/Division 32: End Anchorage Assembly Type CRT	Supplier Product Code:	First Offer - \$3,950.76	4 / each	\$15,803.04	Y
PNC2120194B1-12-70	FDOT/Division 32: End Anchorage Assembly Melt	Supplier Product Code:	First Offer - \$3,779.16	4 / each	\$15,116.64	Y
PNC2120194B1-12-71	FDOT/Division 32: Reset Existing Steel Guardrail	Supplier Product Code:	First Offer - \$27.72	100 / linear foot	\$2,772.00	Y

PNC2120194B1-12-72	FDOT/Division 32: Rip Rap Fabric Formed	Supplier Product Code:	First Offer - \$120.00	50 / square yard	\$6,000.00	Y
PNC2120194B1-12-73	FDOT/Division 32: Detectable Warning	Supplier Product Code:	First Offer - \$48.00	16 / square foot	\$768.00	Y
PNC2120194B1-12-74	FDOT/Division 32: 15 in. dia. Concrete Pipe	Supplier Product Code:	First Offer - \$54.00	100 / linear foot	\$5,400.00	Y
PNC2120194B1-12-75	FDOT/Division 32: 18 in. dia. Concrete Pipe	Supplier Product Code:	First Offer - \$68.40	50 / linear foot	\$3,420.00	Y
PNC2120194B1-12-76	FDOT/Division 32: 24 in. dia. Concrete Pipe	Supplier Product Code:	First Offer - \$96.00	35 / linear foot	\$3,360.00	Y
PNC2120194B1-12-77	FDOT/Division 32: ADA compliant curb ramp	Supplier Product Code:	First Offer - \$600.00	2 / each	\$1,200.00	Y
PNC2120194B1-12-78	FDOT/Division 32: Optional Material	Supplier Product Code:	First Offer - \$36.00	100 / linear foot	\$3,600.00	Y
PNC2120194B1-12-79	FDOT/Division 32: Optional Material	Supplier Product Code:	First Offer - \$42.00	100 / linear foot	\$4,200.00	Y
PNC2120194B1-12-80	FDOT/Division 32: Optional Material	Supplier Product Code:	First Offer - \$60.00	100 / linear foot	\$6,000.00	Y
PNC2120194B1-12-81	FDOT/Division 32: Filling and Plugging Pipe	Supplier Product Code:	First Offer - \$480.00	2 / cubic yard	\$960.00	Y
PNC2120194B1-12-82	FDOT/Division 32: French Drain	Supplier Product Code:	First Offer - \$114.00	25 / linear foot	\$2,850.00	Y
PNC2120194B1-12-83	FDOT/Division 32: Ditch Bottom Type C with grate	Supplier Product Code:	First Offer - \$3,840.00	1 / each	\$3,840.00	Y
PNC2120194B1-12-84	FDOT/Division 32: Ditch Bottom Type C	Supplier Product Code:	First Offer - \$3,840.00	1 / each	\$3,840.00	Y

with Curb Inlet **Code:**

PNC2120194B1-12-85	FDOT/Division 32: Street sign with post	Supplier Product Code:	First Offer - \$918.00	20 / each	\$18,360.00	Y
PNC2120194B1-12-86	FDOT/Division 32: Concrete Car Stop	Supplier Product Code:	First Offer - \$40.80	100 / each	\$4,080.00	Y
PNC2120194B1-12-87	FDOT/Division 32: Pervious Concrete Paving	Supplier Product Code:	First Offer - \$12.00	1500 / square foot	\$18,000.00	Y
PNC2120194B1-12-88	FDOT/Division 32: Permeable Interlocking Concrete Pavers	Supplier Product Code:	First Offer - \$7.34	1200 / square foot	\$8,808.00	Y
PNC2120194B1-12-89	FDOT/Division 32: Security Bollard	Supplier Product Code:	First Offer - \$365.39	4 / each	\$1,461.56	Y
PNC2120194B1-12-90	FDOT/Division 32: Fold-down bollard	Supplier Product Code:	First Offer - \$391.20	4 / each	\$1,564.80	Y

Bid Allowance

\$600,000.00

Lot Total **\$773,902.56**

Item #	Line Item	Notes	Unit Price	Qty/Unit	Attch. Docs
PNC2120194B1-13-01	Division 32 Irrigation: Shrub Adapter	Supplier Product Code:	First Offer - \$24.50	20 / each	\$490.00 Y
PNC2120194B1-13-02	Division 32 Irrigation: Shrub Adapter	Supplier Product Code:	First Offer - \$24.50	20 / each	\$490.00 Y
PNC2120194B1-13-03	Division 32 Irrigation: Pop-up	Supplier Product Code:	First Offer - \$14.09	20 / each	\$281.80 Y
PNC2120194B1-13-04	Division 32 Irrigation: Pop-up	Supplier Product Code:	First Offer - \$20.46	20 / each	\$409.20 Y
PNC2120194B1-13-05	Division 32 Irrigation: Pop-up	Supplier Product	First Offer - \$19.22	20 / each	\$384.40 Y

Code:

PNC2120194B1-13-06	Division 32 Irrigation: Pop-up	Supplier Product Code:	First Offer - \$19.22	20 / each	\$384.40	Y
PNC2120194B1-13-07	Division 32 Irrigation: Pop-up	Supplier Product Code:	First Offer - \$22.75	20 / each	\$455.00	Y
PNC2120194B1-13-08	Division 32 Irrigation: Nozzle	Supplier Product Code:	First Offer - \$16.49	20 / each	\$329.80	Y
PNC2120194B1-13-09	Division 32 Irrigation: Nozzle	Supplier Product Code:	First Offer - \$19.26	20 / each	\$385.20	Y
PNC2120194B1-13-10	Division 32 Irrigation: Bubbler	Supplier Product Code:	First Offer - \$7.58	20 / each	\$151.60	Y
PNC2120194B1-13-11	Division 32 Irrigation: Pop-up	Supplier Product Code:	First Offer - \$81.62	20 / each	\$1,632.40	Y
PNC2120194B1-13-12	Division 32 Irrigation: Pop-up	Supplier Product Code:	First Offer - \$131.45	20 / each	\$2,629.00	Y
PNC2120194B1-13-13	Division 32 Irrigation: Rotor	Supplier Product Code:	First Offer - \$130.01	20 / each	\$2,600.20	Y
PNC2120194B1-13-14	Division 32 Irrigation: QC Valve	Supplier Product Code:	First Offer - \$182.46	10 / each	\$1,824.60	Y
PNC2120194B1-13-15	Division 32 Irrigation: QC Key	Supplier Product Code:	First Offer - \$66.36	5 / each	\$331.80	Y
PNC2120194B1-13-16	Division 32 Irrigation: Rotor and Riser	Supplier Product Code:	First Offer - \$97.16	20 / each	\$1,943.20	Y
PNC2120194B1-13-17	Division 32 Irrigation: Pop-up	Supplier Product Code:	First Offer - \$27.00	20 / each	\$540.00	Y

PNC2120194B1-13-18	Division 32 Irrigation: Electrical Valve	Supplier Product Code:	First Offer - \$258.00	20 / each	\$5,160.00	Y
PNC2120194B1-13-19	Division 32 Irrigation: Electrical Valve	Supplier Product Code:	First Offer - \$312.00	20 / each	\$6,240.00	Y
PNC2120194B1-13-20	Division 32 Irrigation: Electrical Valve	Supplier Product Code:	First Offer - \$630.00	20 / each	\$12,600.00	Y
PNC2120194B1-13-21	Division 32 Irrigation: Electrical Valve	Supplier Product Code:	First Offer - \$393.60	20 / each	\$7,872.00	Y
PNC2120194B1-13-22	Division 32 Irrigation: Electrical Valve	Supplier Product Code:	First Offer - \$606.00	20 / each	\$12,120.00	Y
PNC2120194B1-13-23	Division 32 Irrigation: Electrical Valve	Supplier Product Code:	First Offer - \$630.00	20 / each	\$12,600.00	Y
PNC2120194B1-13-24	Division 32 Irrigation: Relief Valve	Supplier Product Code:	First Offer - \$780.00	10 / each	\$7,800.00	Y
PNC2120194B1-13-25	Division 32 Irrigation: Gate Valve	Supplier Product Code:	First Offer - \$270.00	10 / each	\$2,700.00	Y
PNC2120194B1-13-26	Division 32 Irrigation: Irrigation Controller	Supplier Product Code:	First Offer - \$187.90	1 / each	\$187.90	Y
PNC2120194B1-13-27	Division 32 Irrigation: Irrigation Controller	Supplier Product Code:	First Offer - \$177.28	1 / each	\$177.28	Y
PNC2120194B1-13-28	Division 32 Irrigation: Irrigation Controller	Supplier Product Code:	First Offer - \$348.23	1 / each	\$348.23	Y
PNC2120194B1-13-29	Division 32 Irrigation: Irrigation Controller	Supplier Product Code:	First Offer - \$401.21	1 / each	\$401.21	Y
PNC2120194B1-13-30	Division 32 Irrigation: Irrigation Controller	Supplier Product Code:	First Offer - \$2,931.30	1 / each	\$2,931.30	Y

Code:

PNC2120194B1-13-31	Division 32 Irrigation: Irrigation Controller	Supplier Product Code:	First Offer - \$4,698.78	1 / each	\$4,698.78	Y
PNC2120194B1-13-32	Division 32 Irrigation: Irrigation Controller	Supplier Product Code:	First Offer - \$1,472.80	1 / each	\$1,472.80	Y
PNC2120194B1-13-33	Division 32 Irrigation: Irrigation Controller	Supplier Product Code:	First Offer - \$1,575.78	1 / each	\$1,575.78	Y
PNC2120194B1-13-34	Division 32 Irrigation: Irrigation Controller	Supplier Product Code:	First Offer - \$1,792.50	1 / each	\$1,792.50	Y
PNC2120194B1-13-35	Division 32 Irrigation: Irrigation Controller Grounding	Supplier Product Code:	First Offer - \$1,500.00	5 / each	\$7,500.00	Y
PNC2120194B1-13-36	Division 32 Irrigation: Flow Sensor	Supplier Product Code:	First Offer - \$1,122.95	2 / each	\$2,245.90	Y
PNC2120194B1-13-37	Division 32 Irrigation: Wireless Rain Sensor	Supplier Product Code:	First Offer - \$148.03	2 / each	\$296.06	Y

Bid Allowance

\$600,000.00

Lot Total **\$105,982.34**

Item #	Line Item	Notes	Unit Price	Qty/Unit	Atch. Docs
PNC2120194B1-14-01	Division 33: PVC Drain Basin with grate	Supplier Product Code:	First Offer - \$2,323.49	3 / each	\$6,970.47 Y
PNC2120194B1-14-02	Division 33: PVC Drain Basin with grate	Supplier Product Code:	First Offer - \$2,554.62	3 / each	\$7,663.86 Y
PNC2120194B1-14-03	Division 33: PVC Water Sewer Main	Supplier Product Code:	First Offer - \$48.00	300 / linear foot	\$14,400.00 Y
PNC2120194B1-14-04	Division 33: PVC Water Sewer Main	Supplier Product Code:	First Offer - \$67.02	200 / linear foot	\$13,404.00 Y

PNC2120194B1-14-05	Division 33: DI Water Sewer Main	Supplier Product Code:	First Offer - \$78.00	100 / linear foot	\$7,800.00	Y
PNC2120194B1-14-06	Division 33: DI Water Sewer Main	Supplier Product Code:	First Offer - \$90.00	100 / linear foot	\$9,000.00	Y
PNC2120194B1-14-07	Division 33: DI Water Sewer Main	Supplier Product Code:	First Offer - \$96.00	100 / linear foot	\$9,600.00	Y
PNC2120194B1-14-08	Division 33: Gate Valve with Box	Supplier Product Code:	First Offer - \$1,680.00	10 / each	\$16,800.00	Y
PNC2120194B1-14-09	Division 33: Gate Valve with Box	Supplier Product Code:	First Offer - \$2,268.00	5 / each	\$11,340.00	Y
PNC2120194B1-14-10	Division 33: Gate Valve with Box	Supplier Product Code:	First Offer - \$4,200.00	3 / each	\$12,600.00	Y
PNC2120194B1-14-11	Division 33: Tapping Sleeve and Valve	Supplier Product Code:	First Offer - \$5,640.00	5 / assembly	\$28,200.00	Y
PNC2120194B1-14-12	Division 33: Tapping Sleeve and Valve	Supplier Product Code:	First Offer - \$7,200.00	3 / assembly	\$21,600.00	Y
PNC2120194B1-14-13	Division 33: Tapping Sleeve and Valve	Supplier Product Code:	First Offer - \$9,600.00	2 / assembly	\$19,200.00	Y
PNC2120194B1-14-14	Division 33: Plug Valve	Supplier Product Code:	First Offer - \$3,240.00	3 / each	\$9,720.00	Y
PNC2120194B1-14-15	Division 33: Plug Valve	Supplier Product Code:	First Offer - \$3,600.00	3 / each	\$10,800.00	Y
PNC2120194B1-14-16	Division 33: DDCV for Fire Services	Supplier Product Code:	First Offer - \$11,400.00	2 / assembly	\$22,800.00	Y
PNC2120194B1-14-17	Division 33: DDCV	Supplier	First Offer - \$12,600.00	2 / assembly	\$25,200.00	Y

for Fire Services

**Product
Code:**

PNC2120194B1-14-18	Division 33: DDCV for Fire Services	Supplier Product Code:	First Offer - \$20,400.00	2 / assembly	\$40,800.00	Y
PNC2120194B1-14-19	Division 33: Mechanical Joint Restrains for PVC	Supplier Product Code:	First Offer - \$240.00	30 / each	\$7,200.00	Y
PNC2120194B1-14-20	Division 33: Mechanical Joint Restrains for PVC	Supplier Product Code:	First Offer - \$300.00	30 / each	\$9,000.00	Y
PNC2120194B1-14-21	Division 33: Mechanical Joint Restrains for PVC	Supplier Product Code:	First Offer - \$360.00	20 / each	\$7,200.00	Y
PNC2120194B1-14-22	Division 33: Mechanical Joint Restrains for DI	Supplier Product Code:	First Offer - \$240.00	30 / each	\$7,200.00	Y
PNC2120194B1-14-23	Division 33: Mechanical Joint Restrains for DI	Supplier Product Code:	First Offer - \$300.00	30 / each	\$9,000.00	Y
PNC2120194B1-14-24	Division 33: Mechanical Joint Restrains for DI	Supplier Product Code:	First Offer - \$360.00	20 / each	\$7,200.00	Y
PNC2120194B1-14-25	Division 33: Fire Hydrant	Supplier Product Code:	First Offer - \$4,800.00	4 / each	\$19,200.00	Y
PNC2120194B1-14-26	Division 33: Polyethylene Water Service	Supplier Product Code:	First Offer - \$12.00	100 / linear foot	\$1,200.00	Y
PNC2120194B1-14-27	Division 33: Polyethylene Water Service	Supplier Product Code:	First Offer - \$14.40	300 / linear foot	\$4,320.00	Y
PNC2120194B1-14-28	Division 33: Polyethylene Water Service	Supplier Product Code:	First Offer - \$18.00	300 / linear foot	\$5,400.00	Y
PNC2120194B1-14-29	Division 33: PVC Sch. 40 Water Service	Supplier Product Code:	First Offer - \$12.00	100 / linear foot	\$1,200.00	Y

PNC2120194B1-14-30	Division 33: PVC Sch. 40 Water Service	Supplier Product Code:	First Offer - \$14.40	300 / linear foot	\$4,320.00	Y
PNC2120194B1-14-31	Division 33: PVC Sch. 40 Water Service	Supplier Product Code:	First Offer - \$18.00	300 / linear foot	\$5,400.00	Y
PNC2120194B1-14-32	Division 33: Water Service Connection	Supplier Product Code:	First Offer - \$1,170.00	5 / each	\$5,850.00	Y
PNC2120194B1-14-33	Division 33: Water Service Connection	Supplier Product Code:	First Offer - \$2,340.00	5 / each	\$11,700.00	Y
PNC2120194B1-14-34	Division 33: 1 in. Above Ground RPZ	Supplier Product Code:	First Offer - \$1,600.80	10 / each	\$16,008.00	Y
PNC2120194B1-14-35	Division 33: 2 in. Above Ground RPZ	Supplier Product Code:	First Offer - \$2,160.00	10 / each	\$21,600.00	Y
PNC2120194B1-14-36	Division 33: PVC Water Sewer Service	Supplier Product Code:	First Offer - \$24.00	300 / linear foot	\$7,200.00	Y
PNC2120194B1-14-37	Division 33: Sewer Service	Supplier Product Code:	First Offer - \$18.00	300 / linear foot	\$5,400.00	Y
PNC2120194B1-14-38	Division 33: Sewer Service	Supplier Product Code:	First Offer - \$24.00	300 / linear foot	\$7,200.00	Y
PNC2120194B1-14-39	Division 33: Sewer Service	Supplier Product Code:	First Offer - \$30.00	300 / linear foot	\$9,000.00	Y
PNC2120194B1-14-40	Division 33: Sewer Service	Supplier Product Code:	First Offer - \$36.00	300 / linear foot	\$10,800.00	Y
PNC2120194B1-14-41	Division 33: Sewer Service	Supplier Product Code:	First Offer - \$36.00	300 / linear foot	\$10,800.00	Y
PNC2120194B1-14-42	Division 33: Sewer Service	Supplier Product Code:	First Offer - \$36.00	300 / linear foot	\$10,800.00	Y

Service	Product Code:	Supplier Product Code:	First Offer -	Qty / Unit	Price	Y
PNC2120194B1-14-43	Division 33: PVC Clean-out with Valve Box		\$318.00	15 / each	\$4,770.00	Y
PNC2120194B1-14-44	Division 33: Gate Valve with Valve Box		\$450.00	10 / each	\$4,500.00	Y
PNC2120194B1-14-45	Division 33: Gate Valve with Valve Box		\$474.00	10 / each	\$4,740.00	Y
PNC2120194B1-14-46	Division 33: Sampling Point		\$840.00	20 / each	\$16,800.00	Y
PNC2120194B1-14-47	Division 33: Air Release Valve for Force or Water Main		\$3,600.00	3 / each	\$10,800.00	Y
PNC2120194B1-14-48	Division 33: Lift Station with pump		\$240,000.00	1 / lump sum	\$240,000.00	Y
PNC2120194B1-14-49	Division 33: Concrete Septic Tank		\$10,200.00	1 / lump sum	\$10,200.00	Y
PNC2120194B1-14-50	Division 33: Sanitary Drain field		\$7,300.00	1 / lump sum	\$7,300.00	Y

Bid Allowance

\$600,000.00

Lot Total **\$791,206.33**

Item #	Line Item	Notes	Unit Price	Qty/Unit	Attch. Docs
PNC2120194B1-15-01	Labor and Equipment: Site Grading	Supplier Product Code:	First Offer - \$300.00	30 / hour	\$9,000.00 Y
PNC2120194B1-15-02	Labor and Equipment: Laser Site Grading	Supplier Product Code:	First Offer - \$300.00	30 / hour	\$9,000.00 Y
PNC2120194B1-15-03	Labor and Equipment:	Supplier	First Offer - \$25.75	60 / hour	\$1,545.00 Y

Construction Laborer with
justification

**Product
Code:**

PNC2120194B1--15-04	Labor and Equipment: Electrical Journeyman or Electrician with justification	Supplier Product Code:	First Offer - \$96.00	100 / hour	\$9,600.00	Y
---------------------	--	---------------------------------------	------------------------------	------------	-------------------	----------

PNC2120194B1--15-05	Labor and Equipment: Dump Truck	Supplier Product Code:	First Offer - \$480.00	3 / each	\$1,440.00	Y
---------------------	------------------------------------	---------------------------------------	-------------------------------	----------	-------------------	----------

PNC2120194B1--15-06	Labor and Equipment: Backhoe	Supplier Product Code:	First Offer - \$128.75	12 / hour	\$1,545.00	Y
---------------------	---------------------------------	---------------------------------------	-------------------------------	-----------	-------------------	----------

Bid Allowance			\$600,000.00			
				Lot Total	\$32,130.00	

Item #	Line Item	Notes	Unit Price	Qty/Unit	Attch.	Docs
--------	-----------	-------	------------	----------	--------	------

PNC2120194B1--16-01	General Conditions : General Conditions	Supplier Product Code:	First Offer -	1 / each		Y
---------------------	--	-----------------------------------	----------------------	----------	--	----------

Bid Allowance			\$600,000.00			
				Lot Total	\$0.00	
				Supplier Total	\$6,113,586.07	



EXHIBIT C

Finance and Administrative Services Department
PURCHASING DIVISION

115 S. Andrews Avenue, Room 212 • Fort Lauderdale, Florida 33301 • 954-357-6066 • FAX 954-357-8535

November 16, 2020

TRANSMITTED VIA EMAIL

MBR Construction, Inc.
Attention: Ron Boss
1020 NW 51st Street
Fort Lauderdale, FL 33309
Email: EBROC@mbrconstruction.com

Reference: Contract No. PNC2120194B1_1, Parks Construction and Improvements

Dear Mr. Boss,

This is to confirm that the Board of County Commissioners at its meeting held on November 10, 2020 under Agenda Item No. 42, has conditionally accepted your solicitation response on the subject.

The Contract is in effect for the period beginning **November 10, 2020** and ending **November 9, 2022**. Purchase Order(s) will be placed as and when required.

A copy of this Notice, with a copy of your solicitation response, including all terms and conditions, is being forwarded to all Using Agencies.

Thank you for your interest in doing business with Broward County.

Sincerely,

Brenda J. Billingsley, Director
Purchasing Division

By: **NETANYA F. HOGU**
Digitally signed by
NETANYA F. HOGU
Date: 2020.11.16
11:20:29 -05'00'
Netanya Hogu, Purchasing Agent

C: Amanda Simmens, Construction Project Manager, Highway Construction and Engineering Division

EXHIBIT D

SERINO PARK RESTROOM BUILDING AND PARK IMPROVEMENTS DESIGN / BUILD CRITERIA PACKAGE

STATEMENT OF WORK

The Margate Community Redevelopment Agency, hereinafter referred to as the CRA, intends to retain a qualified, competent, and licensed firm or team to provide the design/build services required for the construction of a new building structure with single stall Male/Female restrooms with janitor's closet and an outdoor drinking fountain/bottle filler; removal of existing playground, installation of new playground with safety surfacing, fitness court equipment, picnic pavilion and other amenities, within an existing public park in the City of Margate. The proposed improvements will be within Serino Park, located at 5600 S.W. 8th Court – Margate, Florida 33068. The general limits of the proposed improvements are displayed within the enclosed Exhibit 1 –Serino Park Site Plan. The proposed work will include seal coating and striping of existing parking lot, plus any new drainage, hardscape, landscape, irrigation, and utilities required by the proposed improvements. A summary of the proposed elements to be incorporated into the proposed Margate Serino Park New Restroom Building and Park Improvements is listed below.

Design/Permit/Construct:

1. Single stall male, single stall female restroom facility, with janitor's closet, and attached or adjacent drinking fountain/bottle filler where shown on Exhibit 1. Exterior bathroom walls to have stone veneer, about 50% from ground level. Offeror shall also include as a bid alternate a double stall (two (2) female stalls and two (2) male stalls).
2. Remove existing playground equipment, shade canopies, sand surfacing, curbing.
3. Install all new playground equipment with 100% shade covering, accessible safety surfacing, and lighting. The playground area shall be reduced to the approximate size as shown on Exhibit 1.
4. All pervious areas of the Park shall be resodded with St. Augustine Floratam Grade A sod.
5. Offeror to construct slab and install shade canopy (100% coverage) over the proposed fitness court and shall install all fitness equipment, to be provided by City or CRA.
6. Seal coat and restripe the existing parking lot.
7. Demolish existing pavilion and install new 20' x 30' pavilion at existing location. (CRA or City will furnish and Offeror shall install 4 tables with benches). Contractor will also install electrical service to the pavilion and include one GFI outlet and security lighting
8. Add 12 Royal Palm trees (20' overall height) at southern property line with decorative up-lighting; add decorative up-lighting to existing trees. No Sabal Palms are to be installed and existing Sabal Palms (if any) shall be removed.
9. Grading, drainage, hardscape, landscape, irrigation and utilities associated with the above improvements.

In its Price Proposal, Offeror shall at minimum provide the cost of each of the above as a separate line item. Further breakdown of costs, such as design, shall be included as appropriate. Separate line items will also be established for permit fee allowance and project contingency. The CRA may include or exclude, in its sole discretion, any of the above items in the final scope of work.

SCOPE OF SERVICES

Successful Offeror, hereinafter referred to as the Offeror, shall enter into an Agreement with the Margate Community Redevelopment Agency, hereinafter referred to as the CRA, for the purpose of the Design/Build of a restroom facility and other park improvements at Serino Park, in the City of Margate. The proposed improvements will be completed within Serino Park, located at 5600 S.W. 8th Court – Margate, Florida 33068, as displayed within **Exhibit 1 – Serino Park Site Plan**. This project includes any site investigation, design document development (design plans, design details, product specifications, and cost estimates), regulatory permitting, and construction in accordance with the terms, conditions, and specifications contained in this Design/Build Criteria Package.

Offeror is requested to provide all necessary professional services, documentation, labor, equipment, materials, insurance, payment and performance bonds, and incidentals required for the design/build of the Serino Park New Restroom Building and Park Improvements. The information contained herein is the minimum that Offeror must address in their Price Proposal. Offeror shall consider all applicable regulatory requirements, industry standards, best practices regarding design and construction standards, and past professional experience in their responses to this Design/Build Criteria Package.

The general scope of the project includes, but is not limited to, the following components:

General Requirements:

- Design/build services required for the construction of a new building structure with Male/Female restrooms and other associated park facilities improvements within an existing public park in the City of Margate. The proposed site for installation of the new playground with shaded covering will be located at just south of the site of the existing playground, which will be demolished by the Offeror. The proposed site for installation of the new fitness court equipment with shade canopy is located at SW segment of Serino Park, along the area fronting State Road-7. The general limits of the proposed Serino Park New Building and Park Facility Improvements are displayed within enclosed **Exhibit 1 – Serino Park Site Plan**. The proposed work will also include seal coating and striping of existing parking lot, together with drainage, hardscape, landscape, irrigation, electric and other utilities associated with the proposed improvements.
- The information provided in **Exhibit 1** is intended to provide Offeror with a general overview of the programming objectives and desired specifications of the CRA. No representation is made as to the accuracy of the information provided, which shall be independently evaluated by Offeror. The final design of the project is the responsibility of Offeror, who is encouraged to provide creative, design alternatives and value engineering, provided that the minimum program objectives are satisfied.
- The Offeror shall be responsible for all work required prior to and after the construction of the proposed improvements under Serino Park New Restroom and Park Improvements, such as permitting approvals, utility coordination, site preparations, site restoration, and project closeout.
- Offeror shall be responsible for all planning, design, permitting, and construction related to any structural, electrical, mechanical, plumbing, utilities, drainage, parking, ADA pathways, fencing, hardscaping, landscaping, and irrigation elements necessary to complete the Serino Park New Restroom and Park Improvements.
- Offeror shall be responsible for all coordination with all applicable regulatory agencies along with all permit submittals, permit fees, and associated costs. Offeror shall obtain a Building Permit approval from the City of Margate Building Department and an Engineering Permit from DEES (if required) for the proposed construction prior to any site work. Any permit fees paid by Offeror to the City of Margate Building Department and/or DEES will be reimbursed by the CRA as a direct pass-through

(i.e. without mark-up). Offeror shall be responsible for any permit or license fees from Broward County or other governmental agencies, which shall also be reimbursed by the CRA as a direct pass-through expense. The CRA shall be responsible for any impact fees for water and sewer if necessary.

- The existing Park is subject to Broward County Surface Water Management License # SWM2005-115-2. Offeror shall be responsible for securing modifications and/or other required approvals under this License.
- The CRA will be responsible for filing the application(s) and processing for all site plan submissions to the City's Development Review Process, which may include the Development Review Committee, the Planning Board, CRA Board and the City Commission. The Offeror shall cooperate with the CRA during this process and shall prepare and provide any surveys, design plans, calculations, and other documentation required for the site plan approval process.
- Offeror acknowledges that the CRA has furnished a current survey of Serino Park, which is enclosed as Exhibit 2.
- Offeror is responsible for inspecting, examining, and verifying the existing conditions at the project location to make adequate provisions and preparation for the construction of the proposed improvements under the Serino Park New Restroom and Park Improvements for the purpose of avoiding any potential horizontal, vertical, underground, or overhead obstructions during construction activities.
- Offeror is responsible for the completion of any surveys, and as-built drawings necessary for project layout, construction, and final certification.
- Offeror shall be responsible for all soil borings, soil bearing analysis, material testing, and engineering reports required for all design, permitting, construction, and certifications related to the proposed construction.
- Offeror is responsible for obtaining available utility atlases, as-built drawings, and/or GIS information from the City of Margate and/or the CRA. Offeror is responsible for ensuring continued operations of the existing sanitary sewer system, existing potable water system, and any other utility service within each project site for entire duration of the project.
- Offeror is responsible for maintaining any existing site drainage and storm water management systems adjacent to project site for entire duration of the project.
- Offeror is responsible for all clearing, grubbing, compaction, and site preparations necessary for the construction of the proposed improvements under the Serino Park New Restroom and Park Improvements project. Offeror shall be responsible for removal and disposal of any unsuitable materials generated by the clearing and grubbing operations. If any existing trees must be removed for the installation, Offeror shall be responsible for obtaining tree removal permit (if necessary).
- Offeror shall coordinate suitable, safe, and clear access for all construction equipment needed for the construction of the proposed improvements under Serino Park New Restroom and Park Improvements. If the path to the proposed locations is over existing utilities, sidewalks, or other damageable areas, the Offeror shall be responsible for providing proper markings, plating, or other appropriate protections to prevent any damage. If there are any overhead obstructions, such as overhead utility lines or existing canopy trees, the Offeror shall be responsible for coordinating and scheduling the de-energizing of any overhead utility lines or trimming of any existing canopy trees.
- Offeror shall be responsible for coordinating and scheduling all site inspections required by the City Building Department related to paving, water connections, electrical connections, structural components, and landscaping installation.
- Offeror is responsible for implementing a stormwater pollution prevention plan throughout the duration of construction activities to provide adequate erosion and sedimentation control on the project site.

- Offeror shall be responsible for all site cleanup, debris removal, and trash removal required during the work duration.
- Offeror shall be responsible for all site restoration of any items impacted by construction activities within and adjacent to the project limits. All items impacted by the construction work, such as existing sidewalks, curbing, driveways, fencing, landscaping, sodding, irrigation, utilities, etc., shall be restored to match the existing conditions or better.
- Offeror is responsible for maintaining continuous safe and adequate pedestrian and vehicular access throughout Serino Park for duration of the project. If required, Offeror shall prepare and provide a Maintenance of Traffic (MOT) plan in accordance with FDOT, Broward County Engineering Division, and MUTCD standards to City for approval prior to construction activities.
- All work shall be completed in accordance with the latest editions of all applicable Federal, State, County, and City codes/regulations, including but not limited to, Sixth Edition (2017) Florida Building Code, Sixth Edition (2017) Florida Building Code Accessibility, Americans with Disabilities Act (ADA), National Fire Protection Association (NFPA), City of Margate Code of Ordinances, Broward County Code of Ordinances, and industry standards if greater than code requirements. If a conflict between any Codes, Regulations, Standards and Criteria is detected, the most stringent shall apply.
- The CRA's schedule for this project, from notice to proceed to substantial completion, will include all planning, design, permitting, and construction activities and will be negotiated during the selection process. Separate schedules will be agreed upon for (a) design, (b) permitting (est.), and (c) construction. For the purposes of this Agreement, final completion for the proposed improvements shall mean closure of all permits, and the issuance of final payment and shall occur within 30 days of substantial completion. The CRA will have the right to include a provision for liquidated damages in the Agreement.
- The CRA's budget for the construction of the proposed improvements under Serino Park New Restroom and Park Improvements will be determined during the evaluation process and negotiated based on cost estimate(s) prepared by Offeror. Offeror's cost estimate shall list each component of the project as a separate line item and shall include a separate contingency of not less than 5% of total cost and an allowance for permit fees.
- The CRA, in its sole discretion, may select or omit any project component in the final Agreement.

List of Exhibits:

<u>Exhibit 1</u>	<u>Serino Park Site Plan</u>
<u>Exhibit 2</u>	<u>Serino Park Survey (2 sheets)</u>
<u>Exhibit 3</u>	<u>Fitness Court Rendering and Slab dimensions (specifically: NFC Tile Slab Drawings Rev-7/6 sheets); Fitness Court Delivery Guidance(1 sheet); USA Shade & Fabric Structure (2 sheets); and 2021 EIS Specification-Pricing (2 sheets))</u>

Prepared by: Arlene Walcott, AICP, and Cotter Christian

Exhibit 1

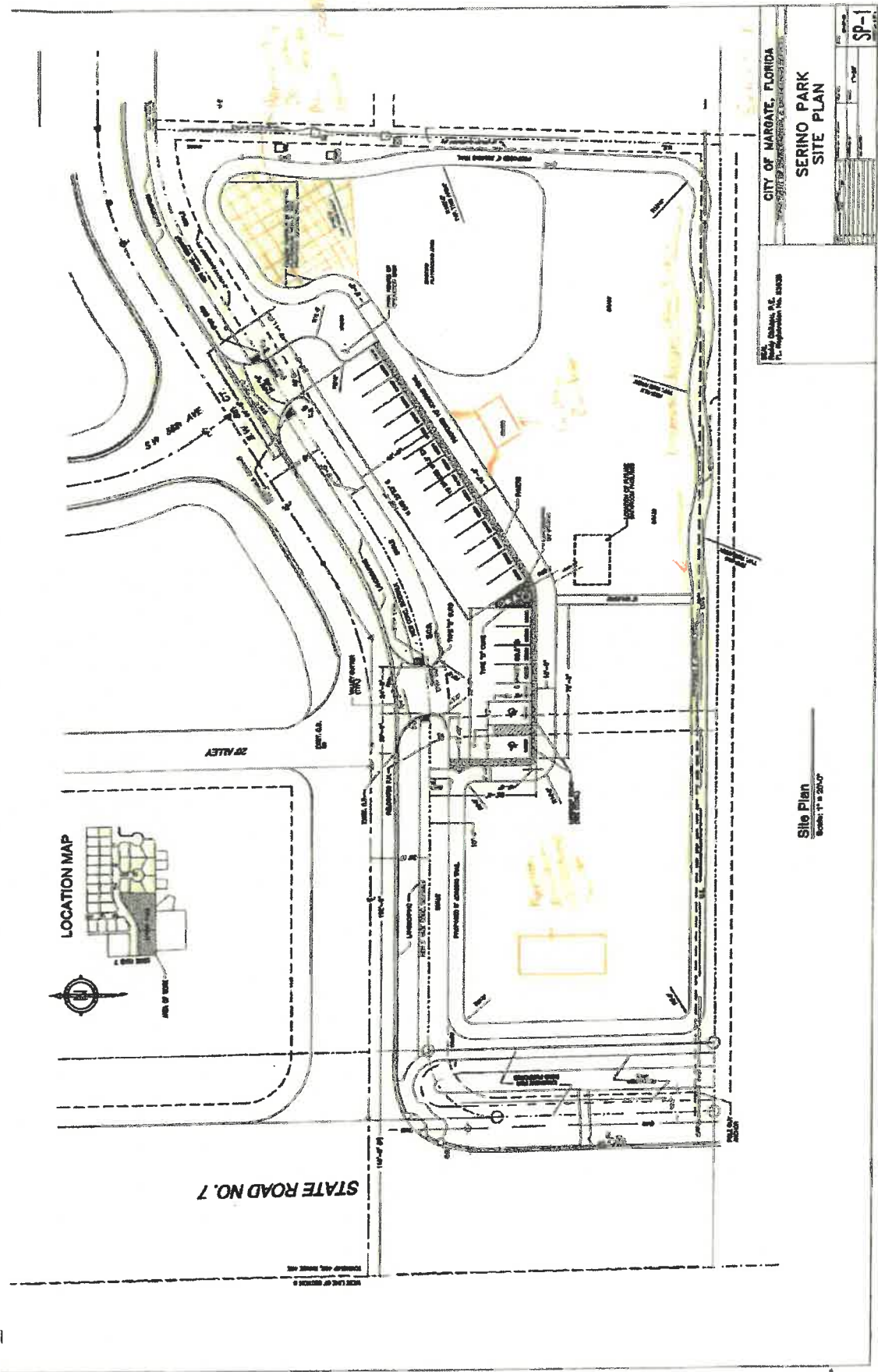

15:30:00 1/1-0022_0010.dwg (craven) 1/1-0022_0010 PLOT CALC.dwg [1] May 24, 2021 8:58:00 PM

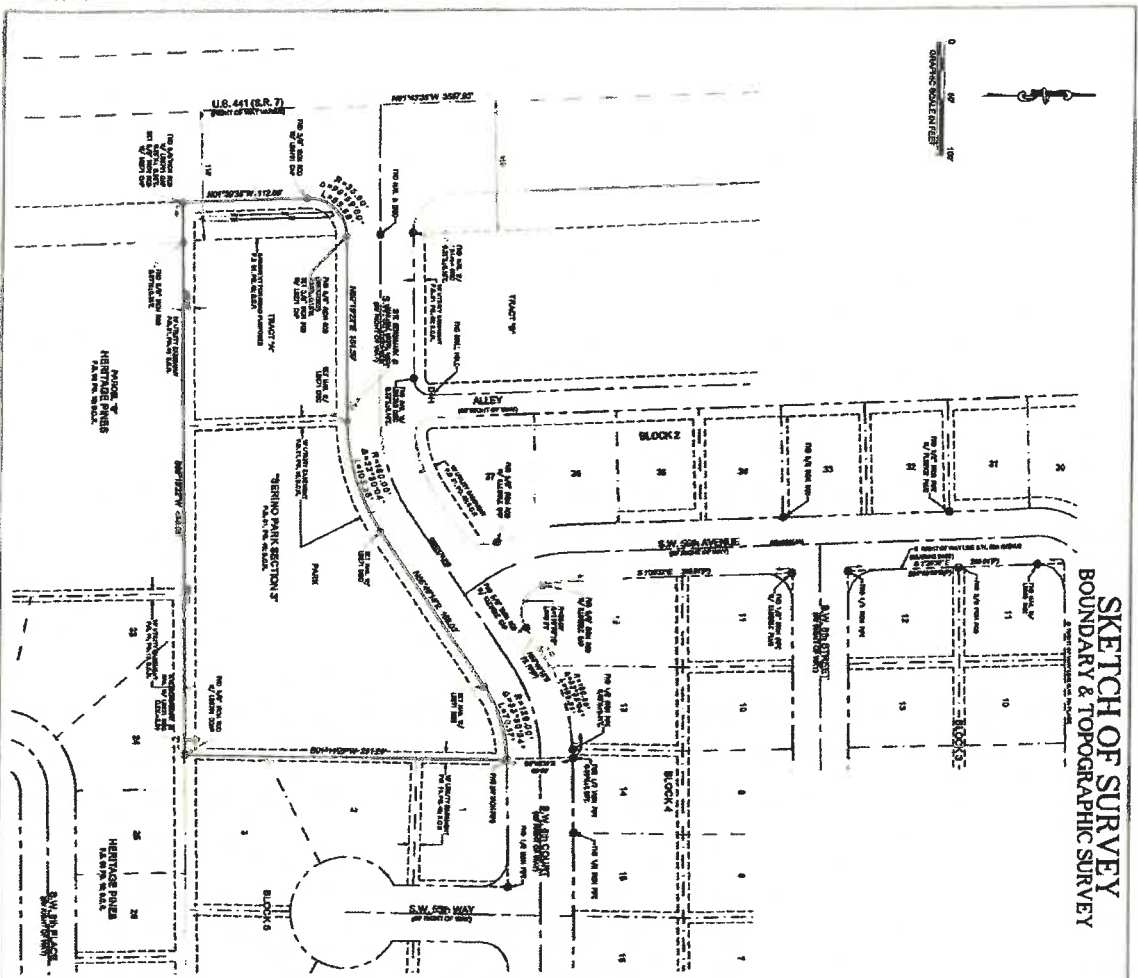

SKETCH OF SURVEY BOUNDARY & TOPOGRAPHIC SURVEY

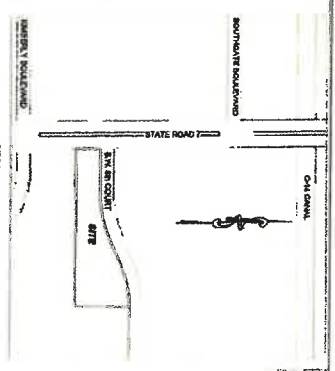

DISCREPANCIES:
 ALL OF THE DATA AND ALL OF THE INFORMATION CONTAINED HEREIN IS THE PROPERTY OF CRAVEN-THOMPSON AND ASSOCIATES, INC. AND IS NOT TO BE REPRODUCED OR TRANSMITTED IN ANY FORM OR BY ANY MEANS, ELECTRONIC OR MECHANICAL, INCLUDING PHOTOCOPYING, RECORDING, OR BY ANY INFORMATION STORAGE AND RETRIEVAL SYSTEM, WITHOUT THE WRITTEN PERMISSION OF CRAVEN-THOMPSON AND ASSOCIATES, INC. ANY REPRODUCTION OR TRANSMISSION OF THIS DOCUMENT WITHOUT THE WRITTEN PERMISSION OF CRAVEN-THOMPSON AND ASSOCIATES, INC. IS STRICTLY PROHIBITED.

SURVEY NOTES:

1. THE SURVEY WAS CONDUCTED BY THE SURVEYOR AND HIS FIELD STAFF ON THE DATE(S) INDICATED ON THE SURVEY PLAN.
2. THE SURVEY WAS CONDUCTED IN ACCORDANCE WITH THE SURVEYING STANDARDS AND PRACTICES OF THE STATE OF FLORIDA.
3. THE SURVEY WAS CONDUCTED USING THE FOLLOWING INSTRUMENTS AND METHODS: [List instruments and methods]
4. THE SURVEY WAS CONDUCTED IN ACCORDANCE WITH THE SURVEYING STANDARDS AND PRACTICES OF THE STATE OF FLORIDA.
5. THE SURVEY WAS CONDUCTED IN ACCORDANCE WITH THE SURVEYING STANDARDS AND PRACTICES OF THE STATE OF FLORIDA.
6. THE SURVEY WAS CONDUCTED IN ACCORDANCE WITH THE SURVEYING STANDARDS AND PRACTICES OF THE STATE OF FLORIDA.
7. THE SURVEY WAS CONDUCTED IN ACCORDANCE WITH THE SURVEYING STANDARDS AND PRACTICES OF THE STATE OF FLORIDA.
8. THE SURVEY WAS CONDUCTED IN ACCORDANCE WITH THE SURVEYING STANDARDS AND PRACTICES OF THE STATE OF FLORIDA.
9. THE SURVEY WAS CONDUCTED IN ACCORDANCE WITH THE SURVEYING STANDARDS AND PRACTICES OF THE STATE OF FLORIDA.
10. THE SURVEY WAS CONDUCTED IN ACCORDANCE WITH THE SURVEYING STANDARDS AND PRACTICES OF THE STATE OF FLORIDA.
11. THE SURVEY WAS CONDUCTED IN ACCORDANCE WITH THE SURVEYING STANDARDS AND PRACTICES OF THE STATE OF FLORIDA.
12. THE SURVEY WAS CONDUCTED IN ACCORDANCE WITH THE SURVEYING STANDARDS AND PRACTICES OF THE STATE OF FLORIDA.
13. THE SURVEY WAS CONDUCTED IN ACCORDANCE WITH THE SURVEYING STANDARDS AND PRACTICES OF THE STATE OF FLORIDA.
14. THE SURVEY WAS CONDUCTED IN ACCORDANCE WITH THE SURVEYING STANDARDS AND PRACTICES OF THE STATE OF FLORIDA.
15. THE SURVEY WAS CONDUCTED IN ACCORDANCE WITH THE SURVEYING STANDARDS AND PRACTICES OF THE STATE OF FLORIDA.

PLANNING'S CERTIFICATE:

I, the undersigned, being duly qualified and licensed as a Professional Engineer in the State of Florida, do hereby certify that the above information is true and correct to the best of my knowledge and belief, and that I am a duly qualified and licensed Professional Engineer in the State of Florida.

Raymond Young
 Digitally signed by Raymond Young
 Date: 2021.05.24 08:58:09 -04'00'

CRAVEN-THOMPSON AND ASSOCIATES, INC.
 ENGINEERS • PLANNERS • SURVEYORS
 2815 N.W. 83RD STREET, FORT LAUDERDALE, FLORIDA 33308
 P.O. BOX 2048, FORT LAUDERDALE, FLORIDA 33308
 PHONE: (954) 333-8888
 FAX: (954) 333-8889
 WWW: WWW.CRAVEN-THOMPSON.COM

DATE: 05/24/21
 SCALE: AS SHOWN
 DRAWN BY: [Name]
 CHECKED BY: [Name]
 PROJECT NO: 21-0022-001-01
 SHEET 1 OF 2

SERINO PARK COURT
 STATE ROAD 7 & S.W. 8th COURT
 MARGATE, FLORIDA
 PREPARED FOR:
 CITY OF MARGATE
 BOUNDARY INFORMATION

CRAVEN-THOMPSON AND ASSOCIATES, INC.
 ENGINEERS • PLANNERS • SURVEYORS
 2815 N.W. 83RD STREET, FORT LAUDERDALE, FLORIDA 33308
 P.O. BOX 2048, FORT LAUDERDALE, FLORIDA 33308
 PHONE: (954) 333-8888
 FAX: (954) 333-8889
 WWW: WWW.CRAVEN-THOMPSON.COM

NO.	DATE	REVISION
1	05/24/21	ISSUED FOR PERMIT

**SKETCH OF SURVEY
BOUNDARY & TOPOGRAPHIC SURVEY**
SEE SHEET V-1 FOR SITE BOUNDARY, IMPROVEMENT, DISPOSITION, ADMINISTER'S NOTES AND CERTIFICATION

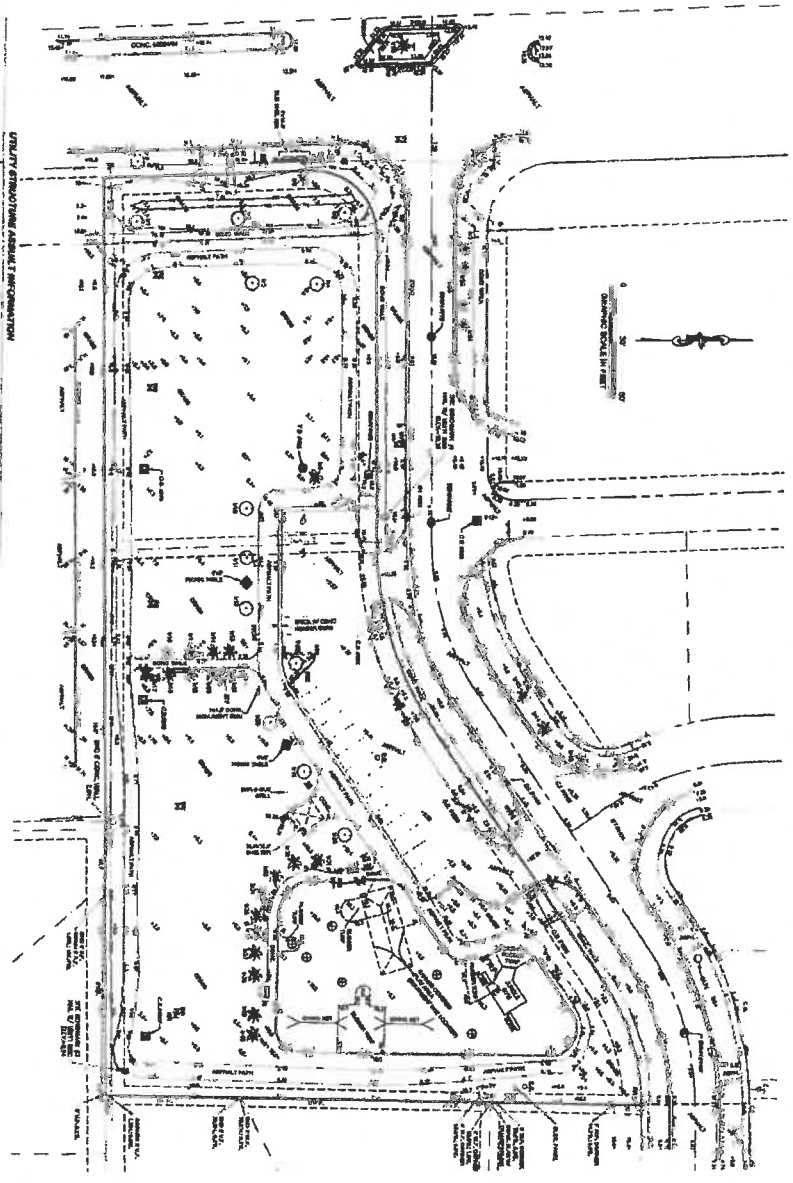

UTILITY EXISTING/PLANNED ASSESSMENT INFORMATION

UTILITY	EXISTING/PLANNED	ASSESSMENT	REMARKS
WATER	EXISTING	12" DIAMETER	10' DEPTH
SEWER	EXISTING	12" DIAMETER	10' DEPTH
ELECTRIC	EXISTING	4" DIAMETER	10' DEPTH
TELEPHONE	EXISTING	4" DIAMETER	10' DEPTH
PLUMBING	EXISTING	4" DIAMETER	10' DEPTH
AC	EXISTING	4" DIAMETER	10' DEPTH
HEATING	EXISTING	4" DIAMETER	10' DEPTH
STORM	EXISTING	18" DIAMETER	10' DEPTH
RAIN	EXISTING	18" DIAMETER	10' DEPTH
WATER	PLANNED	12" DIAMETER	10' DEPTH
SEWER	PLANNED	12" DIAMETER	10' DEPTH
ELECTRIC	PLANNED	4" DIAMETER	10' DEPTH
TELEPHONE	PLANNED	4" DIAMETER	10' DEPTH
PLUMBING	PLANNED	4" DIAMETER	10' DEPTH
AC	PLANNED	4" DIAMETER	10' DEPTH
HEATING	PLANNED	4" DIAMETER	10' DEPTH
STORM	PLANNED	18" DIAMETER	10' DEPTH
RAIN	PLANNED	18" DIAMETER	10' DEPTH

THESE LIST

SYMBOL	DESCRIPTION
1	ADDITIONAL POINT
2	ADDITIONAL POINT
3	ADDITIONAL POINT
4	ADDITIONAL POINT
5	ADDITIONAL POINT
6	ADDITIONAL POINT
7	ADDITIONAL POINT
8	ADDITIONAL POINT
9	ADDITIONAL POINT
10	ADDITIONAL POINT
11	ADDITIONAL POINT
12	ADDITIONAL POINT
13	ADDITIONAL POINT
14	ADDITIONAL POINT
15	ADDITIONAL POINT
16	ADDITIONAL POINT
17	ADDITIONAL POINT
18	ADDITIONAL POINT
19	ADDITIONAL POINT
20	ADDITIONAL POINT
21	ADDITIONAL POINT
22	ADDITIONAL POINT
23	ADDITIONAL POINT
24	ADDITIONAL POINT
25	ADDITIONAL POINT
26	ADDITIONAL POINT
27	ADDITIONAL POINT
28	ADDITIONAL POINT
29	ADDITIONAL POINT
30	ADDITIONAL POINT
31	ADDITIONAL POINT
32	ADDITIONAL POINT
33	ADDITIONAL POINT
34	ADDITIONAL POINT
35	ADDITIONAL POINT
36	ADDITIONAL POINT
37	ADDITIONAL POINT
38	ADDITIONAL POINT
39	ADDITIONAL POINT
40	ADDITIONAL POINT
41	ADDITIONAL POINT
42	ADDITIONAL POINT
43	ADDITIONAL POINT
44	ADDITIONAL POINT
45	ADDITIONAL POINT
46	ADDITIONAL POINT
47	ADDITIONAL POINT
48	ADDITIONAL POINT
49	ADDITIONAL POINT
50	ADDITIONAL POINT
51	ADDITIONAL POINT
52	ADDITIONAL POINT
53	ADDITIONAL POINT
54	ADDITIONAL POINT
55	ADDITIONAL POINT
56	ADDITIONAL POINT
57	ADDITIONAL POINT
58	ADDITIONAL POINT
59	ADDITIONAL POINT
60	ADDITIONAL POINT
61	ADDITIONAL POINT
62	ADDITIONAL POINT
63	ADDITIONAL POINT
64	ADDITIONAL POINT
65	ADDITIONAL POINT
66	ADDITIONAL POINT
67	ADDITIONAL POINT
68	ADDITIONAL POINT
69	ADDITIONAL POINT
70	ADDITIONAL POINT
71	ADDITIONAL POINT
72	ADDITIONAL POINT
73	ADDITIONAL POINT
74	ADDITIONAL POINT
75	ADDITIONAL POINT
76	ADDITIONAL POINT
77	ADDITIONAL POINT
78	ADDITIONAL POINT
79	ADDITIONAL POINT
80	ADDITIONAL POINT
81	ADDITIONAL POINT
82	ADDITIONAL POINT
83	ADDITIONAL POINT
84	ADDITIONAL POINT
85	ADDITIONAL POINT
86	ADDITIONAL POINT
87	ADDITIONAL POINT
88	ADDITIONAL POINT
89	ADDITIONAL POINT
90	ADDITIONAL POINT
91	ADDITIONAL POINT
92	ADDITIONAL POINT
93	ADDITIONAL POINT
94	ADDITIONAL POINT
95	ADDITIONAL POINT
96	ADDITIONAL POINT
97	ADDITIONAL POINT
98	ADDITIONAL POINT
99	ADDITIONAL POINT
100	ADDITIONAL POINT

ABBREVIATION LEGEND

SYMBOL LEGEND

SYMBOL **DESCRIPTION**

- 1. ADDITIONAL POINT
- 2. ADDITIONAL POINT
- 3. ADDITIONAL POINT
- 4. ADDITIONAL POINT
- 5. ADDITIONAL POINT
- 6. ADDITIONAL POINT
- 7. ADDITIONAL POINT
- 8. ADDITIONAL POINT
- 9. ADDITIONAL POINT
- 10. ADDITIONAL POINT
- 11. ADDITIONAL POINT
- 12. ADDITIONAL POINT
- 13. ADDITIONAL POINT
- 14. ADDITIONAL POINT
- 15. ADDITIONAL POINT
- 16. ADDITIONAL POINT
- 17. ADDITIONAL POINT
- 18. ADDITIONAL POINT
- 19. ADDITIONAL POINT
- 20. ADDITIONAL POINT
- 21. ADDITIONAL POINT
- 22. ADDITIONAL POINT
- 23. ADDITIONAL POINT
- 24. ADDITIONAL POINT
- 25. ADDITIONAL POINT
- 26. ADDITIONAL POINT
- 27. ADDITIONAL POINT
- 28. ADDITIONAL POINT
- 29. ADDITIONAL POINT
- 30. ADDITIONAL POINT
- 31. ADDITIONAL POINT
- 32. ADDITIONAL POINT
- 33. ADDITIONAL POINT
- 34. ADDITIONAL POINT
- 35. ADDITIONAL POINT
- 36. ADDITIONAL POINT
- 37. ADDITIONAL POINT
- 38. ADDITIONAL POINT
- 39. ADDITIONAL POINT
- 40. ADDITIONAL POINT
- 41. ADDITIONAL POINT
- 42. ADDITIONAL POINT
- 43. ADDITIONAL POINT
- 44. ADDITIONAL POINT
- 45. ADDITIONAL POINT
- 46. ADDITIONAL POINT
- 47. ADDITIONAL POINT
- 48. ADDITIONAL POINT
- 49. ADDITIONAL POINT
- 50. ADDITIONAL POINT
- 51. ADDITIONAL POINT
- 52. ADDITIONAL POINT
- 53. ADDITIONAL POINT
- 54. ADDITIONAL POINT
- 55. ADDITIONAL POINT
- 56. ADDITIONAL POINT
- 57. ADDITIONAL POINT
- 58. ADDITIONAL POINT
- 59. ADDITIONAL POINT
- 60. ADDITIONAL POINT
- 61. ADDITIONAL POINT
- 62. ADDITIONAL POINT
- 63. ADDITIONAL POINT
- 64. ADDITIONAL POINT
- 65. ADDITIONAL POINT
- 66. ADDITIONAL POINT
- 67. ADDITIONAL POINT
- 68. ADDITIONAL POINT
- 69. ADDITIONAL POINT
- 70. ADDITIONAL POINT
- 71. ADDITIONAL POINT
- 72. ADDITIONAL POINT
- 73. ADDITIONAL POINT
- 74. ADDITIONAL POINT
- 75. ADDITIONAL POINT
- 76. ADDITIONAL POINT
- 77. ADDITIONAL POINT
- 78. ADDITIONAL POINT
- 79. ADDITIONAL POINT
- 80. ADDITIONAL POINT
- 81. ADDITIONAL POINT
- 82. ADDITIONAL POINT
- 83. ADDITIONAL POINT
- 84. ADDITIONAL POINT
- 85. ADDITIONAL POINT
- 86. ADDITIONAL POINT
- 87. ADDITIONAL POINT
- 88. ADDITIONAL POINT
- 89. ADDITIONAL POINT
- 90. ADDITIONAL POINT
- 91. ADDITIONAL POINT
- 92. ADDITIONAL POINT
- 93. ADDITIONAL POINT
- 94. ADDITIONAL POINT
- 95. ADDITIONAL POINT
- 96. ADDITIONAL POINT
- 97. ADDITIONAL POINT
- 98. ADDITIONAL POINT
- 99. ADDITIONAL POINT
- 100. ADDITIONAL POINT

PROJECT NO. 2140022-001-01 V-2 SHEET 2 OF 2	SERINO PARK STATE ROAD 7 & S.W. 8th COURT MARGATE, FLORIDA	CRAVEN - THOMPSON AND ASSOCIATES, INC. ENGINEERS • PLANNERS • SURVEYORS 5865 N.W. 83RD STREET, FORT LAUDERDALE, FLORIDA 33309 TEL: (954) 336-4466 FAX: (954) 336-4468	DATE: 02/21/11 SCALE: 1" = 40' DRAWING BY: JY CHECKED BY: KDC FILED BY: JLB PLOTTED BY: JLB
	PREPARED FOR CITY OF MARGATE SITE IMPROVEMENT LOCATIONS		DESCRIPTION:

CONCRETE SLAB PLAN & CROSS-SECTION

(FOR FLAT TOP SLAB / TILE FLOOR INSTALLATION)

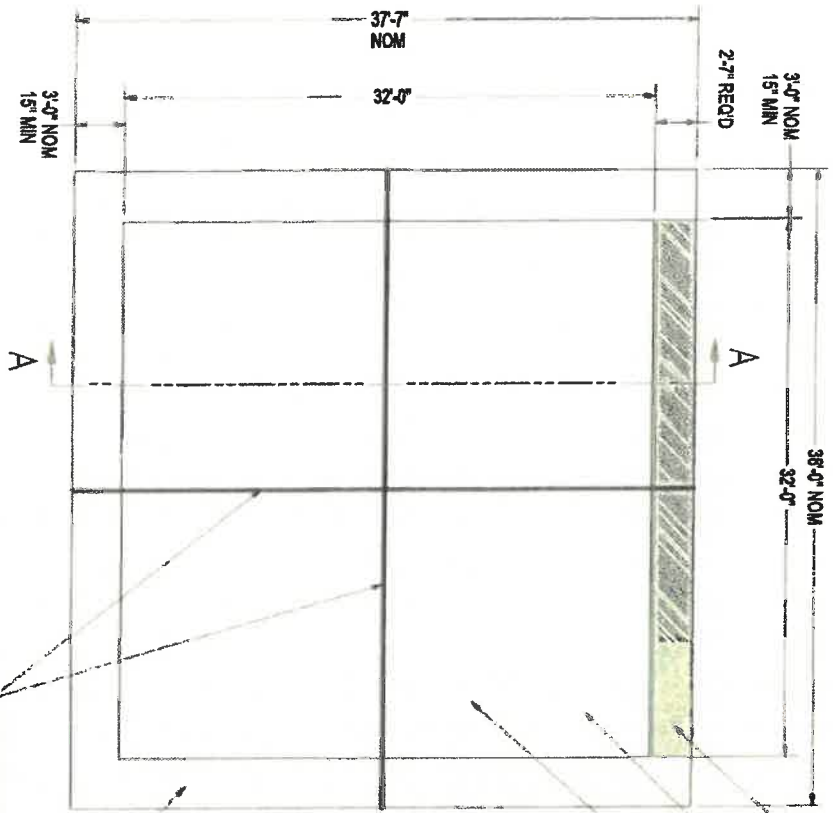

— FITNESS COURT BODY WEIGHT TRAINING WALL INSTALLATION AREA BY OTHERS

— FITNESS COURT TILED EXERCISE FLOOR AREA, TILE FLOOR BY OTHERS.

— THE FINISHED CONCRETE SURFACE SHOULD BE SMOOTH TO PREVENT IRREGULARITIES, ROUGHNESS, OR OTHER DEFECTS THAT WOULD AFFECT THE FINISHED FLOOR SURFACE. THE SURFACE SHOULD BE FLAT TO THE EQUIVALENT OF 3/16" OVER 10'. THE FINISHED CONCRETE SURFACE SHOULD HAVE A LIGHT BROOM FINISH TO PROVIDE THE BEST SURFACE FOR COURT SURFACE ADHESION.

FOR INSTALLATIONS THAT REQUIRE FLOORING INSTALLATION SOON (LESS THAN 30 DAYS) AFTER CONCRETE PLACEMENT, APPLICATION OF SPRAWLOCK PRODUCT SGP 327 OR EQUIVALENT IS REQUIRED. THE SPRAWLOCK PRODUCT WILL ALLOW FLOORING INSTALLATION AS SOON AS 14 DAYS AFTER CONCRETE PLACEMENT AND SPRAWLOCK APPLICATION. CONFIRM PRODUCT SELECTION WITH THE MANUFACTURER. APPLY SPRAWLOCK PRODUCT THE DAY OF THE CONCRETE PLACEMENT PER MANUFACTURER'S INSTRUCTIONS.

— FITNESS COURT BODY WEIGHT TRAINING WALL INSTALLATION AREA BY OTHERS

AWAY FROM WALL TO OPPOSITE EDGE OF SLAB

▲ SLOPE 1/8" PER 12"

SECTION A-A (ROTATED)

4" MINIMUM SLAB THICKNESS FOR REQUIRED ANCHOR CLEARANCE



— SLAB SIZE MAY BE ADJUSTED TO PROVIDE THE BAND WIDTH SHOWN AROUND THE PERIMETER OF THE TILED COURT SURFACE. A NARROW 1'-0" BAND MAY BE UTILIZED WITH A SHADE STRUCTURE. ANY SHADE STRUCTURE (BY OTHERS) SHALL HAVE ITS OWN INDEPENDENT FOUNDATIONS.

THIS DOCUMENT IS PROPERTY OF IFC. ONE NATIONAL FITNESS CAMPAIGN. THIS DOCUMENT CONTAINS CONFIDENTIAL AND PROPRIETARY INFORMATION AND IS NOT TO BE REPRODUCED OR TRANSMITTED IN ANY FORM OR BY ANY MEANS, ELECTRONIC OR MECHANICAL, INCLUDING PHOTOCOPYING, RECORDING, OR BY ANY INFORMATION STORAGE AND RETRIEVAL SYSTEM. PERMISSION TO REPRODUCE THIS DOCUMENT IS NOT GRANTED WITHOUT THE PRIOR WRITTEN PERMISSION OF IFC.



DATE: 10/29/2020
BY: MARCHIS
DRAWINGS
NAME: TILE SLAB
REV: 7/26/22 25

NATIONAL FITNESS CAMPAIGN
SAN FRANCISCO, CA



REINFORCEMENT / PREP DETAIL

(FOR FLAT TOP SLAB / TILE FLOOR INSTALLATION)

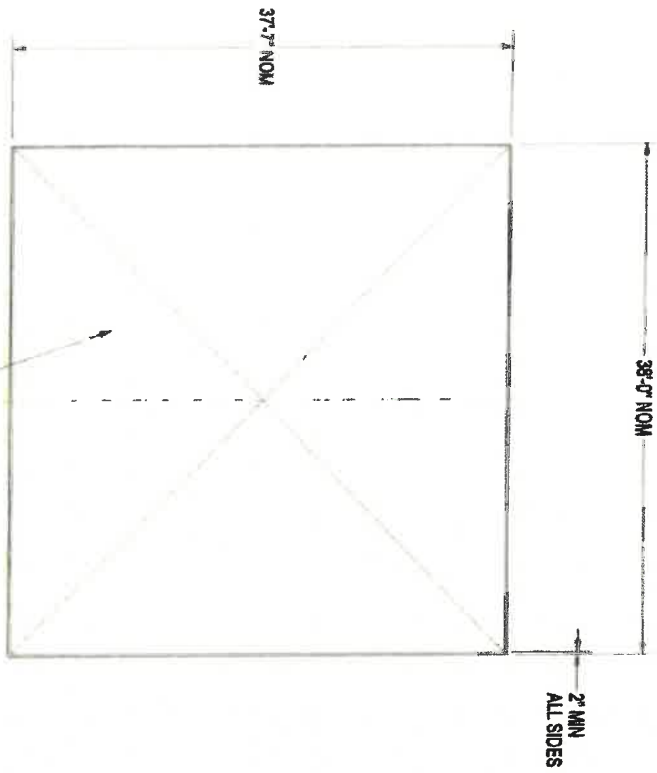

REINFORCING TO BE 6 X 6 X 66 WELDED WIRE MESH (WWM) PLACED IN THE CENTER OF THE SLAB TO EXTEND THROUGH ENTIRE SLAB. UTILIZE SUFFICIENT NUMBER OF CHAIRS TO MAINTAIN WWM POSITION. INSTALL ADDITIONAL REINFORCEMENT AS REQUIRED BY LOCAL CODE.

PREP SECTION DETAIL

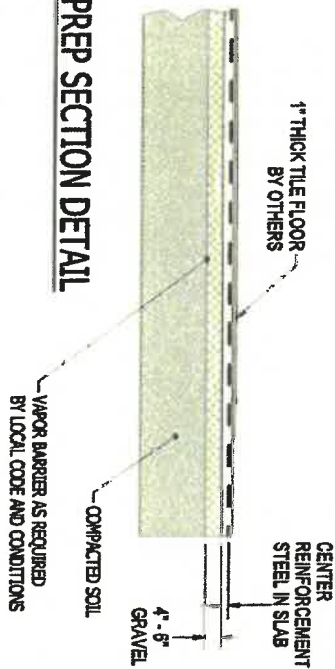

THIS DOCUMENT IS PROPERTY OF IIRC THE NATIONAL FITNESS CAMPAIGN. THIS DOCUMENT CONTAINS CONFIDENTIAL AND PROPRIETARY INFORMATION AND MAY ONLY BE USED BY PERMISSION FROM IIRC AND FOR THE PURPOSES AUTHORIZED BY IIRC. IIRC CANNOT BE REPRODUCED, MODIFIED, OR OTHERWISE USE OF THIS DOCUMENT IS NOT PERMITTED WITHOUT THE PRIOR WRITTEN PERMISSION OF IIRC.



DATE: 10/29/2020
 BY: MARCUS INNOVATIONS
 NAME: TILE SLAB
 REV: 7 PAGE: 3/6

NATIONAL FITNESS CAMPAIGN

SAN FRANCISCO, CA

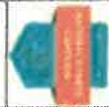

ANCHOR DETAILS FOR TILE

APPLIES TO TILE INSTALLATION ONLY.
REQUEST ALTERNATE DRAWING FOR FOUR-BLACE.
ALSO SEE ANCHOR NOTES ON SLAB NOTES DRAWING.

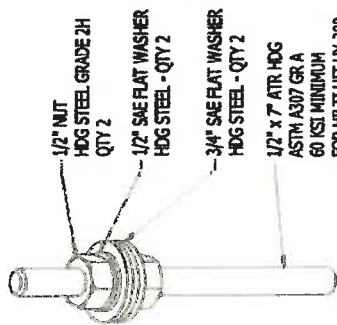
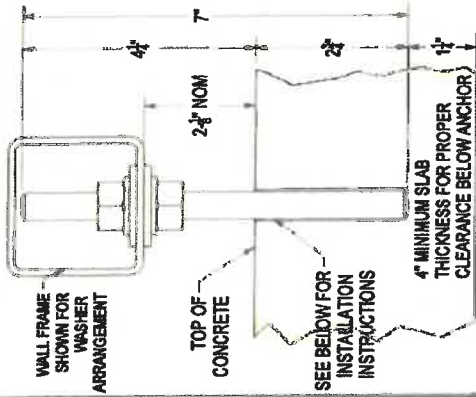

ANCHOR A
WALL ANCHOR
DRILL 9/16" HOLE IN CONCRETE
FOR 2-3/4" EMBEDMENT

FLAT AND LOCK WASHERS ON TOP OF EQUIPMENT PLATE
STEEL BASE PLATE OF EQUIPMENT
BOTTOM SURFACE OF TILE FLOOR AND TOP OF CONCRETE
SEE BELOW FOR INSTALLATION INSTRUCTIONS

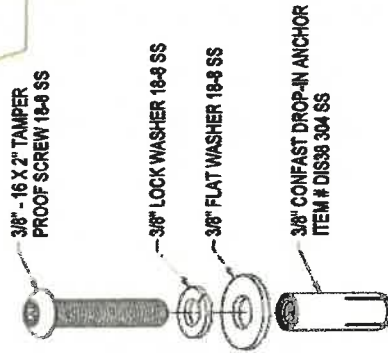

DRILL 1/2" HOLE IN CONCRETE
FOR 1-9/16" EMBEDMENT

ANCHOR B
DROP-IN ANCHOR

ANCHOR HOLE INSTRUCTIONS

1. DRILL HOLES FOR ANCHORS TO SPECIFIED DIAMETER AND DEPTH
2. USE COMPRESSED AIR TO REMOVE CONCRETE DUST AND DEBRIS FROM HOLES PRIOR TO ANCHOR INSTALLATION
3. REFER TO FITNESS COURT INSTALLATION INSTRUCTIONS FOR ADDITIONAL ANCHOR INSTALLATION STEPS



THIS DOCUMENT IS PROPERTY OF IFC (THE NATIONAL FITNESS CAMPAIGN). THIS DOCUMENT CONTAINS CONFIDENTIAL AND PROPRIETARY INFORMATION AND MAY ONLY BE USED BY PERMISSION FROM IFC AND FOR THE PURPOSES AUTHORIZED BY IFC. DISCLOSURE, DUPLICATION, REPRODUCTION, OR OTHER USE OF THIS DOCUMENT IS NOT PERMITTED WITHOUT THE PRIOR WRITTEN PERMISSION OF IFC.

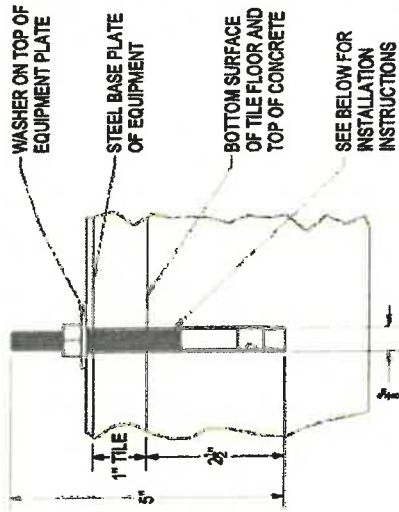

3/8" X 5" CONFAST WEDGE ANCHOR
ITEM # WAG305 HDG STEEL
EXPANSION ANCHOR
DRILL 3/8" HOLE
IN CONCRETE FOR
2-5/16" EMBEDMENT

ANCHOR C
MECHANICAL ANCHOR

ANCHOR A EPOXY NOTE:
ANCHOR A MUST BE INSTALLED WITH THE ANCHOR EPOXY SPECIFIED OR ACCEPTABLE ALTERNATIVE. HILTI HY-200 IS RECOMMENDED. ALTERNATE EPOXY SIMPSON SET-3P IS ACCEPTABLE FOR NEW UNCRACKED CONCRETE ONLY. ALTERNATE EPOXY SIKHA ANCHORFDX-2 IS ACCEPTABLE FOR NEW, UNCRACKED CONCRETE ONLY. FOLLOW EPOXY MANUFACTURERS INSTALLATION PROCEDURES.



WALL ANCHOR LOCATIONS (FLOOR ANCHORS SHOWN ON SEPARATE DRAWING)

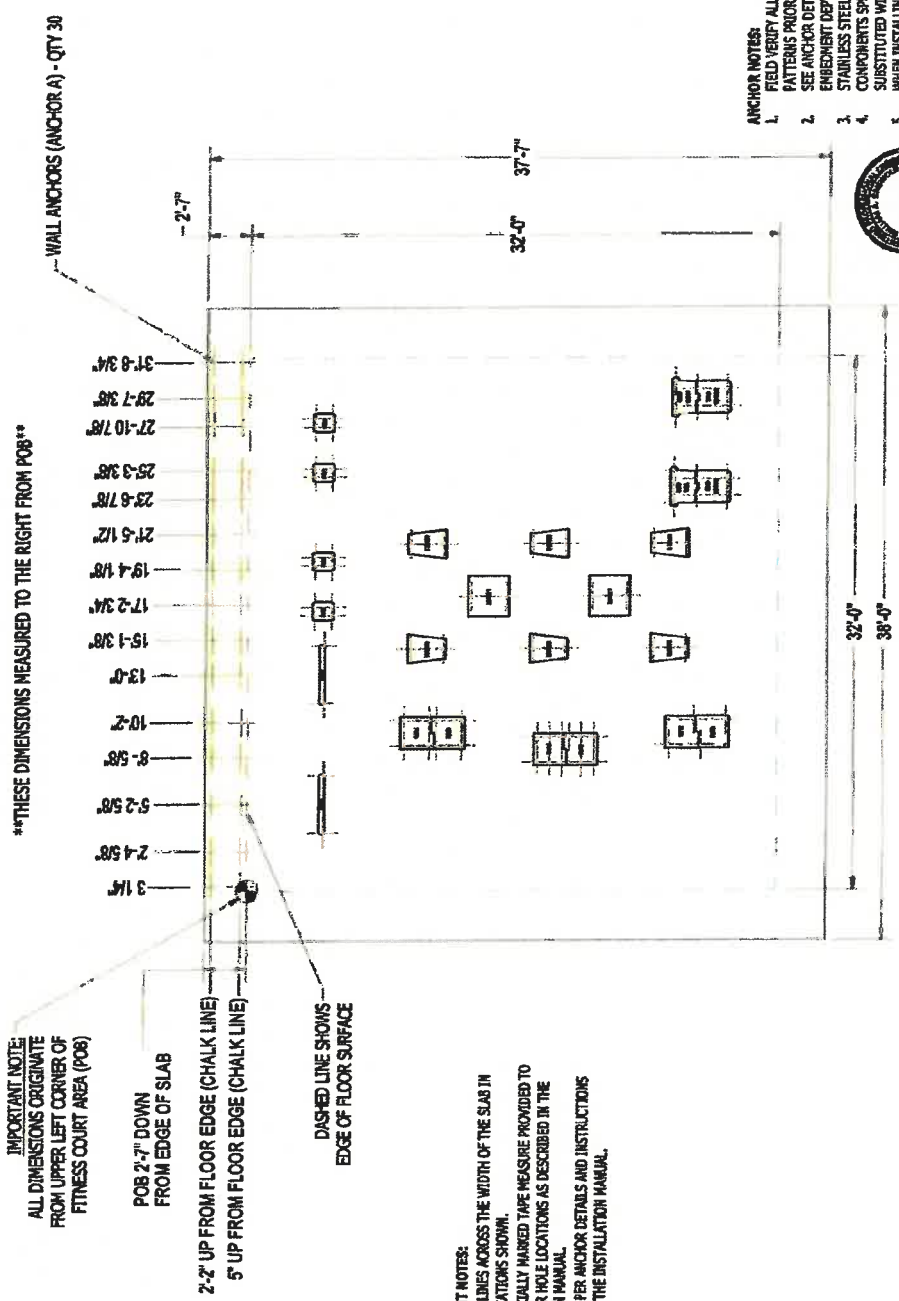

THESE DIMENSIONS MEASURED TO THE RIGHT FROM POB

IMPORTANT NOTE:
ALL DIMENSIONS ORIGINATE FROM UPPER LEFT CORNER OF FITNESS COURT AREA (POB)

POB 2'-7" DOWN FROM EDGE OF SLAB

2'-2" UP FROM FLOOR EDGE (CHALK LINE)
5" UP FROM FLOOR EDGE (CHALK LINE)

DASHED LINE SHOWS EDGE OF FLOOR SURFACE

ANCHOR PLACEMENT NOTES:

1. PLACE CHALK LINES ACROSS THE WIDTH OF THE SLAB IN THE TWO LOCATIONS SHOWN.
2. USE THE SPECIALLY MARKED TAPE MEASURE PROVIDED TO MARK ANCHOR HOLE LOCATIONS AS DESCRIBED IN THE INSTALLATION MANUAL.
3. PLACE HOLES PER ANCHOR DETAILS AND INSTRUCTIONS PROVIDED BY THE INSTALLATION MANUAL.

ANCHOR NOTES:

1. FIELD VERIFY ALL ANCHOR LOCATION DIMENSIONS AND PATTERNS PRIOR TO DRILLING.
2. SEE ANCHOR DETAILS FOR APPLICABLE CONCRETE EMBEDMENT DEPTH AND HOLE DIAMETER.
3. STAINLESS STEEL MUST BE USED WHERE SPECIFIED.
4. COMPONENTS SPECIFIED AS HOT-DIP GALVANIZED MAY BE SUBSTITUTED WITH 304 SS COMPONENTS.
5. WHEN INSTALLING ANCHORS, TAKE CARE TO USE THREAD PROTECTORS TO PREVENT THREAD DAMAGE.



THIS DOCUMENT IS PROPERTY OF IFC (THE NATIONAL FITNESS CAMPAIGN). THIS DOCUMENT CONTAINS CONFIDENTIAL AND PROPRIETARY INFORMATION AND MAY ONLY BE USED BY PERMISSION FROM IFC AND FOR THE PURPOSES AUTHORIZED BY IFC. DISCLOSURE, DUPLICATION, REPRODUCTION, OR OTHER USE OF THIS DOCUMENT IS NOT PERMITTED WITHOUT THE PRIOR WRITTEN PERMISSION OF IFC.

FLOOR ANCHOR LOCATIONS

(NOTED FOR TILE FLOOR INSTALLATION)
(WALL ANCHORS SHOWN ON SEPARATE DRAWING)

THESE DIMENSIONS MEASURED TO THE RIGHT FROM POB

LOCATION OF UPPER LEFT ANCHORS SHOWN FOR EACH PIECE OF EQUIPMENT. LOCATE UPPER LEFT HOLE AND USE TEMPLATES OR EQUIPMENT TO LOCATE REMAINING HOLES. SEE TEMPLATE NOTES BELOW.

IMPORTANT: PUSH STATION ANCHORS ARE TO BE LOCATED AFTER WALL PLACEMENT AND PUSH STATIONS ARE PLACED IN FINAL LOCATION

PLYO BOX 1 AND 2
4 ANCHORS PER BOX IN OUTSIDE CORNERS PER CENTER MARKS

PLYO BOX 3 AND 4
6 ANCHORS PER BOX IN ALL TEMPLATE HOLES PER CENTER MARKS

ANCHOR QTY NOTES:
PUSH STATION - QTY 2 PER STATION - 4 TOTAL
ROW STATION - QTY 4 PER STATION - 16 TOTAL
PLYO BOX STATIONS - SEE QTY PER BOX BELOW - 24 TOTAL
PB1 - QTY 4 ANCHORS, 1 IN EACH CORNER
PB2 - QTY 4 ANCHORS, 1 IN EACH CORNER
PB3 - QTY 6 ANCHORS, 1 IN EACH HOLE
PB4 - QTY 6 ANCHORS, 1 IN EACH HOLE
PB5 - QTY 2 ANCHORS, 1 IN EACH OPPOSITE CORNER
PB6 - QTY 2 ANCHORS, 1 IN EACH OPPOSITE CORNER
LUNGE STATION 1 - QTY 2 PER STATION - 4 TOTAL
LUNGE STATION 2 - QTY 2 PER STATION - 12 TOTAL
TALL BEND STATION - QTY 6 PER STATION - 6 TOTAL
SHORT BEND STATION - QTY 6 PER STATION - 6 TOTAL

THIS DOCUMENT IS PROPERTY OF HFC (THE NATIONAL FITNESS CAMPAIGN). THIS DOCUMENT CONTAINS CONFIDENTIAL AND PROPRIETARY INFORMATION AND MAY ONLY BE USED BY PERMISSION FROM HFC AND FOR THE PURPOSES AUTHORIZED BY HFC. DISCLOSURE, DUPLICATION, REPRODUCTION, OR OTHER USE OF THIS DOCUMENT IS NOT PERMITTED WITHOUT THE PRIOR WRITTEN PERMISSION OF HFC.

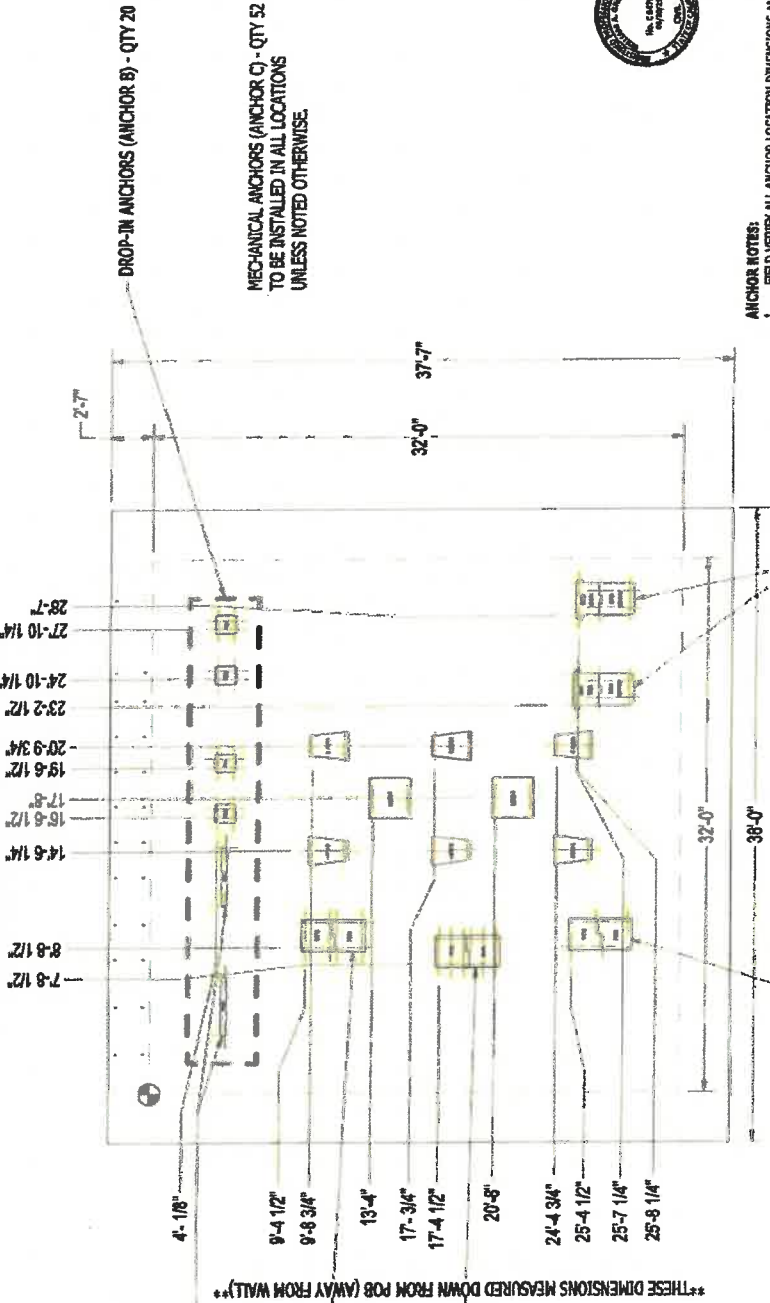

THESE DIMENSIONS MEASURED DOWN FROM POB (AWAY FROM WALL)

DROP-IN ANCHORS (ANCHOR B) - QTY 20

MECHANICAL ANCHORS (ANCHOR C) - QTY 52 TO BE INSTALLED IN ALL LOCATIONS UNLESS NOTED OTHERWISE.



ANCHOR NOTES:

1. FIELD VERIFY ALL ANCHOR LOCATION DIMENSIONS AND PATTERNS PRIOR TO DRILLING.
2. DRILL THROUGH TILE FLOOR (1" TILE THICKNESS) WITH THE APPROPRIATE DRILL BIT TO MATCH THE ANCHOR HOLE PER ANCHOR DETAILS DRAWINGS.
3. SEE ANCHOR DETAILS FOR APPLICABLE CONCRETE EMBEDMENT DEPTH AND HOLE DIAMETER.
4. STAINLESS STEEL MUST BE USED WHERE SPECIFIED.
5. COMPONENTS SPECIFIED AS HOT-DIP GALVANIZED MAY BE SUBSTITUTED WITH 304 SS COMPONENTS.
6. WHEN INSTALLING ANCHORS, TAKE CARE TO USE THREAD PROTECTORS TO PREVENT THREAD DAMAGE.

TEMPLATE NOTES:

- IMPORTANT: PAPER TEMPLATES ARE PROVIDED FOR PLYO BOXES AND BEND STATIONS ONLY
- PUSH STATION - USE THE EQUIPMENT TO MARK ANCHOR LOCATIONS PER INSTRUCTIONS
- ROW STATION - USE THE EQUIPMENT TO MARK ANCHOR LOCATIONS PER INSTRUCTIONS
- PLYO BOX STATIONS - USE THE PAPER TEMPLATE (QTY 1 PROVIDED) TO MARK ALL ANCHORS FOR ALL 6 PLYO BOXES. NOTE QTY OF ANCHORS PER BOX ARE DIFFERENT FOR EACH PLYO BOX.
- LUNGE STATION 1 - USE THE EQUIPMENT TO MARK ANCHOR LOCATIONS PER INSTRUCTIONS
- LUNGE STATION 2 - USE THE EQUIPMENT TO MARK ANCHOR LOCATIONS PER INSTRUCTIONS
- BEND STATIONS - USE THE PAPER TEMPLATE (QTY 1 PROVIDED) TO MARK ALL ANCHORS FOR BOTH BEND STATIONS. NOTE THE DIFFERENCE IN LOCATION FOR THE TALL AND SHORT BEND STATIONS.

PLYO BOX 5 AND 6
2 ANCHORS PER BOX IN OPPOSITE CORNERS UPPER LEFT AND LOWER RIGHT PER CENTER MARKS



The Fitness Court® — Shipping and Delivery Information

Information below is designed to familiarize you with the storage, unloading and packaging of the Fitness Court, to help identify an appropriate location for acceptance of delivery.

Feel free to reach out to your Partnership Activation contact with any questions.

Total Weight: 8.5k lbs = 2k lbs (Crate) + 4k lbs (Court boxes) + 2.5k lbs (Tilt pallets)

Packaging: The Fitness Court will arrive in a large crate (9' x 5' x 5'), with an additional 40 boxes outside of the crate, some on pallets. The Fitness Court Tile and The Fitness Court Installation Kit will arrive on 3 additional pallets, wrapped separately.

Storage: The approximate storage requirements are 15' x 15'. In most cases, we recommend indoor storage, as the cardboard boxes are susceptible to weather damage.

For unloading, you will want to have 4-5 people and a loading dock. A forklift is required. IF YOU DO NOT HAVE A LOADING DOCK: You will also need an industrial pallet jack, rated for at least 3,000 lbs, to transport the crate and pallets to the edge of the truck, for the forklift to unload.

Photo 1: Court loaded for shipment



Photo 2: Typical storage configuration



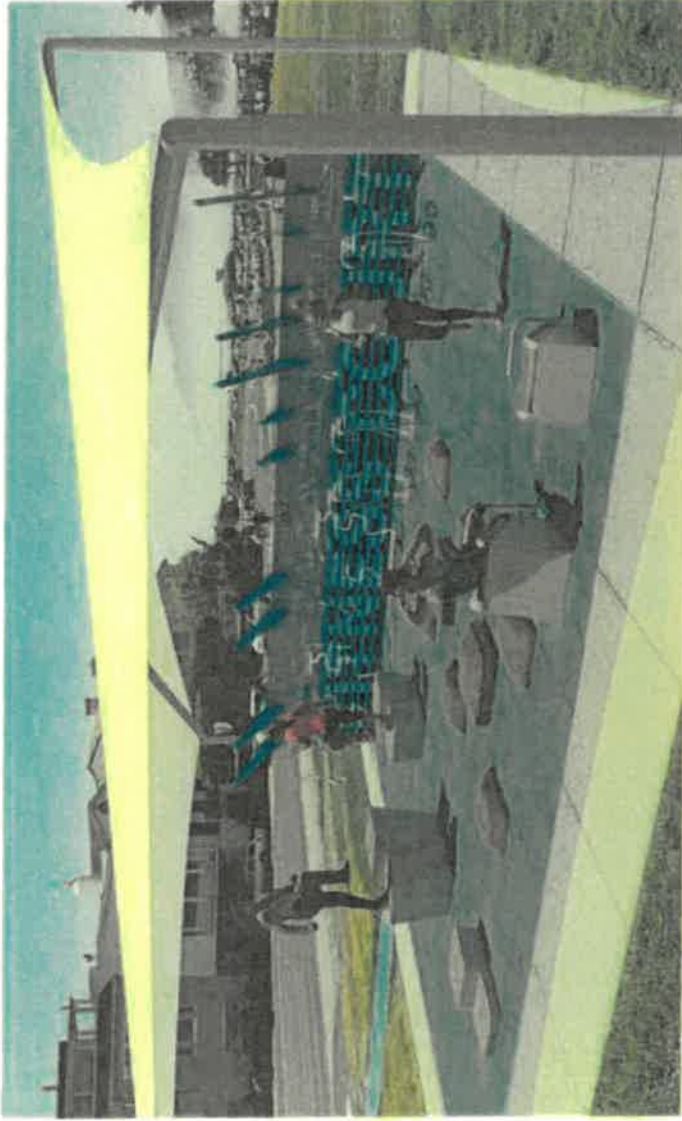

Fitness Court Shade Structures

USA SHADE is the official shade structure provider of the National Fitness Campaign. This shade structure has been designed specifically for the Fitness Court®, integrating beautifully with form and function.

For more information about the National Fitness Campaign, visit: www.nationalfitnesscampaign.com



Increases Use



UV Protection



Designed for the Fitness Court®



Highest Quality Aesthetics



Durable Fabrics



Need shade for your Fitness Court?
Contact Whitney Klen at wklen@usa-shade.com
(1214) 883-8823

Copyright © 2014 by USA Shade Structures, Inc. All rights reserved.

Fitness Court Shade Structure

This document is intended to provide an estimated total budget for developing and implementing a shade structure over the 'The Fitness Court' with USASHADE in collaboration with the National Fitness Campaign.



USA SHADE is the official shade structure sponsor of National Fitness Campaign. This unique shade structure has been designed specifically for the Fitness Court®, integrating beautifully with form and function.

Fitness Court® shade structures employ durable fabrics to boost UV protection, heighten aesthetics and increase overall use of the Fitness Court®.



Color Package

Post Option:
Powder coated steel



Quick View

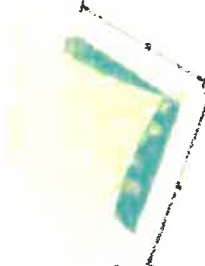

Side Profile



Extreme UV fabrics carry a 10 year limited manufacturer warranty from the date of installation against failure from significant fading, deterioration, breakdown, rips/tears, rubber feet, cold or discoloration.

STRUCTURE FUNDS + INSTALLATION

Shade Structure: \$22,000

- 41'x41' Fabric Shade Structure
- 4 Powder Coated Steel Columns
- Galvanized Tension Cables
- Custom Color Design

Installation: (Estimate May Vary per Location) \$15,000

- Site Prep and Excavation
- Labor Cost for install of Shade Structure

Shipping and Handlings: (Estimate May Vary per Location) \$3,000

TOTAL ESTIMATED FUNDING REQUIRED: \$40,000



Official Installation Partner



Guaranteed Completion in 4 Days or Less *(weather permitting)*

Competitive Flat Rate
Travel Expenses Included

All Flooring Labor Included

Art & Decal Installation Included

Once the concrete slab is poured, EIS is your all-in-one support team for the installation of the Fitness Court® equipment elements, body-weight training wall, and sports floor. With various installations all over the country, EIS is NFC's #1 recommended installer*.

***EIS contracted separately.**



NFC is proud to partner with Engineered Installation Solutions (EIS), our official factory install team, exclusively available for Fitness Court® installations across the country!

Engineered Installation Solutions are Fitness Court® Experts

EIS has comprehensive knowledge of the Fitness Court®. The same people who install the Fitness Court® have worked with NFC to develop the equipment, streamline fabrication and create the installation documents. You will not find an installer who knows more about your Fitness Court®

EIS has the experience to make your installation easy and predictable. EIS will work with you to uncover all the potential obstacles prior to the installation, will schedule the installation to meet your needs and will certify the installation is complete per NFC installation instructions. EIS provides a high level of value and quality.

The Fitness Court® - Installation Specifications

Certified National Fitness Campaign Fitness Court® installs are secured through Engineered Installation Solutions.

The following items are included in the Fitness Court® installation:

- Sports Floor Tile
- Body-weight Training Wall
- Equipment Elements
- Anchor Bolts
- Floor Marking Painting
- Art & Vinyl Decals on front, back, and sides of wall
- Signed Certificate of Completed Installation (includes walk-through with Owner / Client)

The following items are *Not Included* in the installation

- Concrete slab built & cured, according to provided slab drawing specification.
- Procurement / supply of The Fitness Court®, Fitness Court® Tile, and Fitness Court® Installation Kit.

Items to Coordinate with Owner / Client Prior to Installation

- Delivery of the Fitness Court® material
- Security of the site (fence or barrier)
- Plan for debris & trash removal

Fitness Court Warranty

- Warranty ratified upon receipt of Signed Certificate of Completed Installation

Total Funding Requirement: \$25,000.00

Supporting Documentation

- NFC provided concrete slab drawings
- The Fitness Court® Tile overview
- The Fitness Court® Specifications
- The Fitness Court® Installation Kit overview
- The Fitness Court® Installation and Maintenance Manual
- The Fitness Court® Vinyl Artwork Alignment Guide

Tim Gunnels
President

(803) 493-9048 tgunnels@enginestall.com

Craig Ausrud

Vice President/ Operations Manager
(704) 770-6602 | causrud@enginestall.com



www.enginestall.com