



SURVEYING & MAPPING
Prepared by: Jeff S. Hodapp, P.S.M.
Certificate of Authorization No. LB7264
947 Clint Moore Road
Boca Raton, Florida 33487
Tel: (561) 241-9988
Fax: (561) 241-5182

NOVE OF MARGATE

A SUBDIVISION RESURVEY OF PARCEL 3 AND A PORTION OF PARCEL 4, "ORIOLE GOLF AND TENNIS CLUB SECTION TWO" ACCORDING TO THE PLAT THEREOF AS RECORDED IN PLAT BOOK 78 PAGE 21 OF THE PUBLIC RECORDS OF BROWARD COUNTY, FLORIDA. BEING A PORTION OF SECTION 35 TOWNSHIP 48 SOUTH, RANGE 41 EAST CITY OF MARGATE, BROWARD COUNTY, FLORIDA.

LEGAL DESCRIPTION

PARCEL 3, "ORIOLE GOLF AND TENNIS CLUB SECTION TWO", ACCORDING TO THE PLAT THEREOF AS RECORDED IN PLAT BOOK 78, PAGE 21, OF THE PUBLIC RECORDS OF BROWARD COUNTY, FLORIDA.

TOGETHER WITH:

A PORTION OF PARCEL 4 OF SAID PLAT, "ORIOLE GOLF AND TENNIS CLUB SECTION TWO", ACCORDING TO THE PLAT THEREOF, AS RECORDED IN PLAT BOOK 78, PAGE 21, OF THE PUBLIC RECORDS OF BROWARD COUNTY, FLORIDA, MORE PARTICULARLY DESCRIBED AS FOLLOWS:

COMMENCING AT THE NORTHWEST CORNER OF SECTION 35, TOWNSHIP 48 SOUTH, RANGE 41 EAST; THENCE SOUTH 00°03'23" WEST, 292.60 FEET ALONG THE WEST BOUNDARY OF SAID SECTION TO THE POINT OF INTERSECTION WITH THE SOUTH RIGHT-OF-WAY LINE OF MARGATE BLVD. ACCORDING TO SAID PLAT; THENCE ALONG SAID SOUTH RIGHT-OF-WAY LINE OF MARGATE BLVD. THE FOLLOWING FOUR (4) COURSES: SOUTH 89°56'37" EAST, 15.94 FEET; THENCE ALONG THE ARC OF A TANGENT CURVE, BEING CONCAVE TO THE SOUTHWEST, HAVING A RADIUS OF 664.05 FEET, A DELTA OF 39°51'40", AN ARC DISTANCE OF 461.98 FEET; THENCE TANGENT TO SAID CURVE SOUTH 50°04'57" EAST, 725.16 FEET; THENCE ALONG THE ARC OF A TANGENT CURVE, CONCAVE TO THE NORTHEAST, HAVING A RADIUS OF 776.33 FEET, A DELTA OF 22°15'10", AN ARC DISTANCE OF 301.52 FEET TO THE NORTHEAST CORNER OF SAID PARCEL 3 AND THE POINT OF BEGINNING; THENCE CONTINUE ALONG SAID CURVE, HAVING A RADIUS OF 776.33 FEET, A DELTA OF 11°58'05", AN ARC DISTANCE OF 162.18 FEET (THE PRECEDING COURSE BEING COINCIDENT WITH THE SAID SOUTH RIGHT-OF-WAY LINE OF MARGATE BLVD.); THENCE SOUTH 20°36'41" WEST, 134.67 FEET; THENCE NORTH 88°35'00" WEST, 115.00 FEET TO A POINT OF THE EAST LINE OF SAID PARCEL 3, THENCE NORTH 01°25'00" EAST ALONG THE EAST LINE OF SAID PARCEL 3, A DISTANCE OF 156.02 FEET TO THE POINT OF BEGINNING.

SAID LANDS SITUATE IN THE CITY OF MARGATE, BROWARD COUNTY, FLORIDA AND CONSISTS OF 21.302 ACRES MORE OR LESS.

DEDICATION

KNOW ALL MEN BY THESE PRESENTS, MARGATE EXECUTIVE GOLF COURSE LLC, A FLORIDA LIMITED LIABILITY COMPANY, OWNER OF THE LANDS DESCRIBED AND SHOWN HEREON, HAS CAUSED SAID LANDS TO BE SUBDIVIDED AS SHOWN HEREON, TO BE KNOWN AS NOVE OF MARGATE.

- 1. TRACTS A-1 AND A-2 ARE HEREBY DEDICATED FOR PRIVATE RECREATIONAL USE TO MARGATE EXECUTIVE GOLF COURSE LLC, A FLORIDA LIMITED LIABILITY COMPANY, ITS SUCCESSORS AND/OR ASSIGNS.
2. TRACTS B-1 AND B-2 ARE HEREBY DEDICATED FOR OPEN SPACE PURPOSES TO MARGATE EXECUTIVE GOLF COURSE LLC, A FLORIDA LIMITED LIABILITY COMPANY, ITS SUCCESSORS AND/OR ASSIGNS.
3. TRACT C IS HEREBY DEDICATED FOR DRAINAGE PURPOSES TO MARGATE EXECUTIVE GOLF COURSE LLC, A FLORIDA LIMITED LIABILITY COMPANY, ITS SUCCESSORS AND/OR ASSIGNS.
4. TRACT L IS HEREBY DEDICATED FOR LAKE PURPOSES TO MARGATE EXECUTIVE GOLF COURSE LLC, A FLORIDA LIMITED LIABILITY COMPANY, ITS SUCCESSORS AND/OR ASSIGNS.
5. TRACT P-1 AND P-2 ARE HEREBY DEDICATED FOR PUBLIC PARK PURPOSES.
6. TRACT R IS HEREBY DEDICATED AS A PRIVATE ROAD TRACT, FOR INGRESS AND EGRESS, UTILITIES, DRAINAGE AND PRIVATE ROAD PURPOSES. A PERPETUAL NON-EXCLUSIVE EASEMENT OVER, ACROSS AND THROUGH TRACT R FOR VEHICULAR AND PEDESTRIAN INGRESS AND EGRESS IS HEREBY GRANTED TO THE PRESENT AND FUTURE OWNERS OF THE LOTS DESCRIBED IN THIS SUBDIVISION RESURVEY.
7. THE UTILITY EASEMENTS ARE HEREBY DEDICATED TO PUBLIC AND PRIVATE UTILITY PROVIDERS AS DEFINED BY FLORIDA LAW FOR THE CONSTRUCTION, INSTALLATION, MAINTENANCE, REPAIR, REPLACEMENT AND OPERATION OF ELECTRIC, TELEPHONE, CABLE TELEVISION, FIBER OPTIC, GAS, COMMUNICATION, SECURITY, WATER AND SEWER SYSTEMS.
8. THE PUBLIC DRAINAGE EASEMENTS ARE DEDICATED TO THE PUBLIC FOR DRAINAGE PURPOSES.
9. THE DRAINAGE EASEMENTS ARE DEDICATED FOR DRAINAGE PURPOSES.
10. THE LAKE MAINTENANCE EASEMENT IS DEDICATED FOR LAKE MAINTENANCE PURPOSES.
11. THE FIRE ACCESS EASEMENT IS DEDICATED FOR FIRE ACCESS PURPOSES.
12. THE FLOWAGE EASEMENT IS DEDICATED TO THE CITY OF MARGATE FOR DRAINAGE AND FLOWAGE PURPOSES.

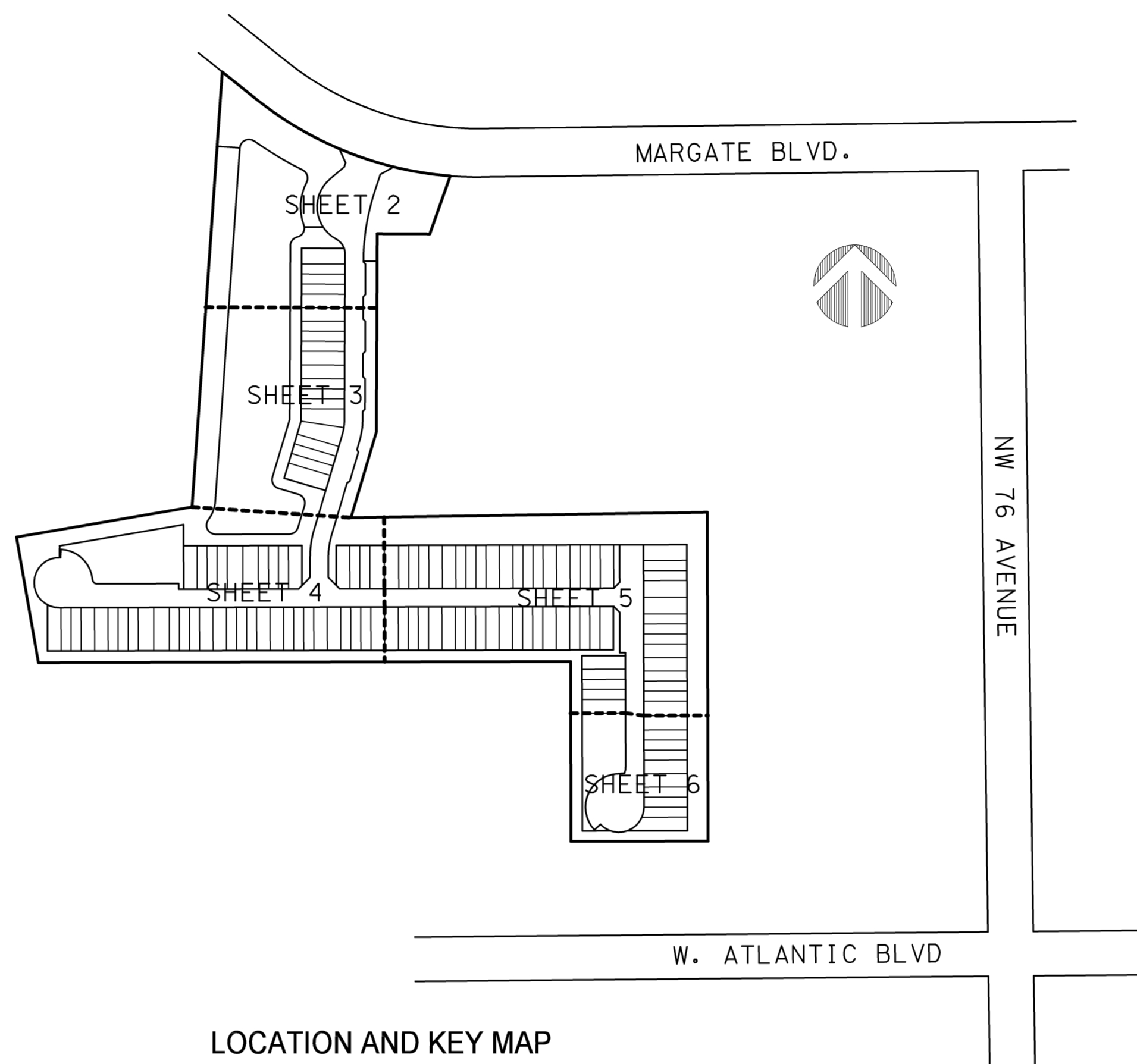

LOCATION AND KEY MAP NOT TO SCALE

CLERK OF COURT CERTIFICATION

FILED FOR RECORD IN THE OFFICE OF THE CLERK OF THE CIRCUIT COURT FOR THE COUNTY OF BROWARD, STATE OF FLORIDA, IN MISCELLANEOUS MAP BOOK PAGE ON THE DAY OF 202.

CLERK OF THE CIRCUIT COURT BROWARD COUNTY, FLORIDA

CITY OF MARGATE

PLANNING AND ZONING BOARD

THIS IS TO CERTIFY THAT THE CITY PLANNING AND ZONING BOARD OF MARGATE, FLORIDA, HAS HEREBY ACCEPTED AND APPROVED THIS SUBDIVISION RESURVEY ON THIS DAY OF 202.

BY: SHEKHANAH AWOFADJU-MAJOR CHAIRMAN

CITY COMMISSION:

THIS IS TO CERTIFY THAT THIS SUBDIVISION RESURVEY, NOVE OF MARGATE, HAS BEEN ACCEPTED AND APPROVED FOR RECORD BY THE CITY COMMISSION OF THE CITY OF MARGATE, FLORIDA, IN AND BY RESOLUTION NO. ADOPTED BY SAID CITY COMMISSION ON THIS DAY OF 202.

IN WITNESS WHEREOF, THE SAID CITY COMMISSION HAS CAUSED THESE PRESENTS TO BE ATTESTED BY ITS CITY CLERK AND THE CORPORATE SEAL OF SAID CITY TO BE AFFIXED THIS DAY OF 202.

BY: JENNIFER M. JOHNSON CITY CLERK

BY: TOMMY RUZZANO MAYOR

CITY ENGINEER

THIS SUBDIVISION RESURVEY IS APPROVED FOR RECORD THIS DAY OF 202.

BY: CURT A. KEYSER, P.E., DIRECTOR DEPARTMENT OF ENVIRONMENTAL AND ENGINEERING SERVICES

SURVEYOR'S CERTIFICATE

I HEREBY CERTIFY THAT THIS SPECIFIC PURPOSE SURVEY (SUBDIVISION RESURVEY) IS A TRUE AND CORRECT REPRESENTATION OF THE LANDS RECENTLY SURVEYED UNDER MY RESPONSIBLE DIRECTION AND SUPERVISION, THAT THE SURVEY DATA SHOWN HEREON CONFORMS TO THE APPLICABLE REQUIREMENTS OF RULE 5J-17, FLORIDA ADMINISTRATIVE CODE.

DATE: JEFF S. HODAPP PROFESSIONAL SURVEYOR AND MAPPER FLORIDA REGISTRATION NO. L.S.5111 PERIMETER SURVEYING & MAPPING, INC. CERTIFICATE OF AUTHORIZATION NUMBER L.B.7264

MARGATE EXECUTIVE GOLF COURSE LLC A FLORIDA LIMITED LIABILITY COMPANY (PRINT NAME) WITNESS

(PRINT NAME) BY: WITNESS

ACKNOWLEDGEMENT

STATE OF FLORIDA ) SS COUNTY OF BROWARD ) THE FOREGOING INSTRUMENT WAS ACKNOWLEDGED BEFORE ME BY MEANS OF PHYSICAL PRESENCE OR ONLINE NOTARIZATION, THIS DAY OF 202, BY AS FOR MARGATE EXECUTIVE GOLF COURSE LLC, A FLORIDA LIMITED LIABILITY COMPANY, ON BEHALF OF THE COMPANY, WHO IS PERSONALLY KNOWN TO ME OR HAS PRODUCED AS IDENTIFICATION.

MY COMMISSION EXPIRES: , NOTARY PUBLIC

SURVEYOR'S NOTE

- 1. THE BEARINGS SHOWN HEREON ARE BASED ON THE NORTHERLY WEST LINE OF PARCEL 3 OF SAID "ORIOLE GOLF AND TENNIS CLUB SECTION TWO" HAVING A GRID BEARING OF N 03°58'34" E, ACCORDING TO STONER KEITH RESURVEY OF ALL OF TOWNSHIP 48 SOUTH RANGE 41 EAST (MISC P.B. 3, PG. 44, B.C.R.) AS TRANSFORMED TO THE NORTH AMERICAN DATUM 1983 WITH THE 1990 ADJUSTMENT.

TITLE INFORMATION

TITLE COMMITMENT PREPARED BY FIDELITY NATIONAL TITLE INSURANCE COMPANY COMMITMENT DATE: DECEMBER 13, 2017 AT 11:00 PM SCHEDULE B-II

Table with 5 columns: #, BOOK/PAGE, DESCRIPTION, APPLIES?, PLOTTED? containing survey details.

\* TO BE RELEASED @ EASEMENT IS BLANKET IN NATURE

Table with 4 columns: OWNER, CITY OF MARGATE, CITY ENGINEER, SURVEYOR

# PERIMETER

## SURVEYING & MAPPING

Prepared by: Jeff S. Hodapp, P.S.M.  
Certificate of Authorization No. LB7264  
947 Clint Moore Road  
Boca Raton, Florida 33487  
Tel: (561) 241-9988  
Fax: (561) 241-5182

# NOVE OF MARGATE

A SUBDIVISION RESURVEY OF PARCEL 3 AND A PORTION OF PARCEL 4, "ORIOLE GOLF AND TENNIS CLUB SECTION TWO" ACCORDING TO THE PLAT THEREOF AS RECORDED IN PLAT BOOK 78 PAGE 21 OF THE PUBLIC RECORDS OF BROWARD COUNTY, FLORIDA. BEING A PORTION OF SECTION 35 TOWNSHIP 48 SOUTH, RANGE 41 EAST CITY OF MARGATE, BROWARD COUNTY, FLORIDA.

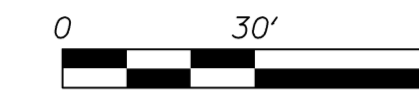
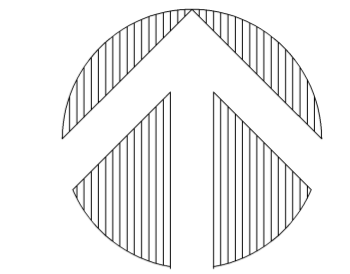

GRAPHIC SCALE  
1"=30'

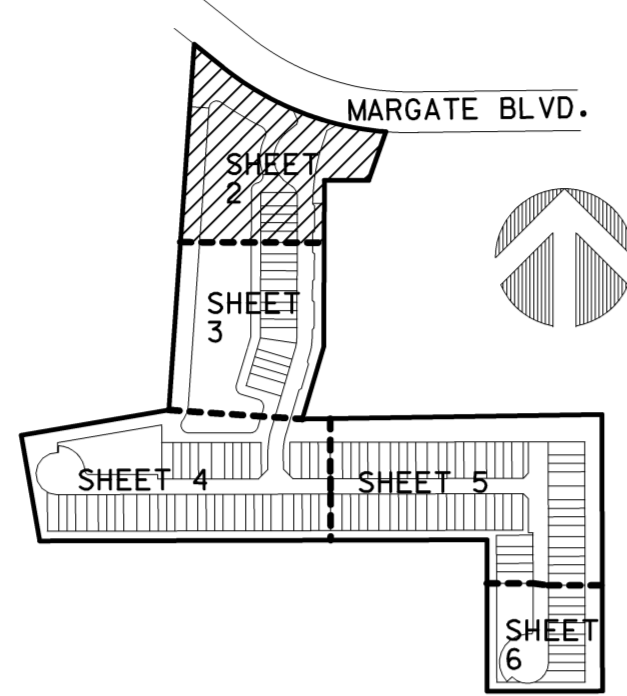

KEY MAP  
NOT TO SCALE

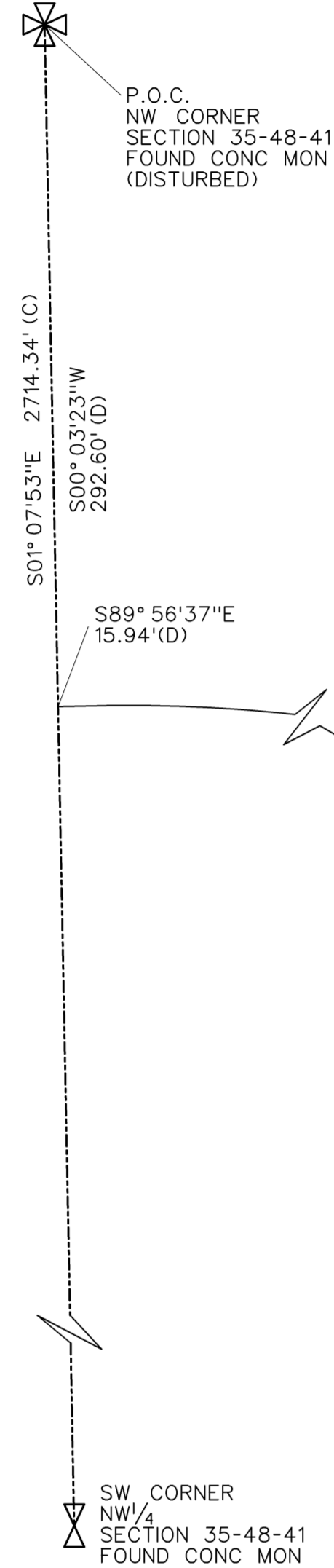

DETAIL

### ABBREVIATIONS:

- B.C.R. = BROWARD COUNTY RECORDS
- CONC. = CONCRETE
- D = DELTA (CENTRAL ANGLE)
- D.E. = DRAINAGE EASEMENT
- F.P.L. = FLORIDA POWER & LIGHT CO.
- L = ARC LENGTH
- L.B. = LICENSED BUSINESS
- L.S. = LICENSED SURVEYOR
- MON. = MONUMENT
- O.R.B. = OFFICIAL RECORDS BOOK
- P.B. = PLAT BOOK
- P.G. = PAGE
- P.O.B. = POINT OF BEGINNING
- P.O.C. = POINT OF COMMENCEMENT
- P.R.M. = PERMANENT REFERENCE MONUMENT
- P.S.M. = PROFESSIONAL SURVEYOR & MAPPER
- R = RADIUS
- R/W = RIGHT-OF-WAY
- SF = SQUARE FEET
- U.E. = UTILITY EASEMENT
- N/D = NAIL AND DISK
- P.D.E. = PUBLIC DRAINAGE EASEMENT
- L.M.E. = LAKE MAINTENANCE EASEMENT
- N.R. = NON-RADIAL

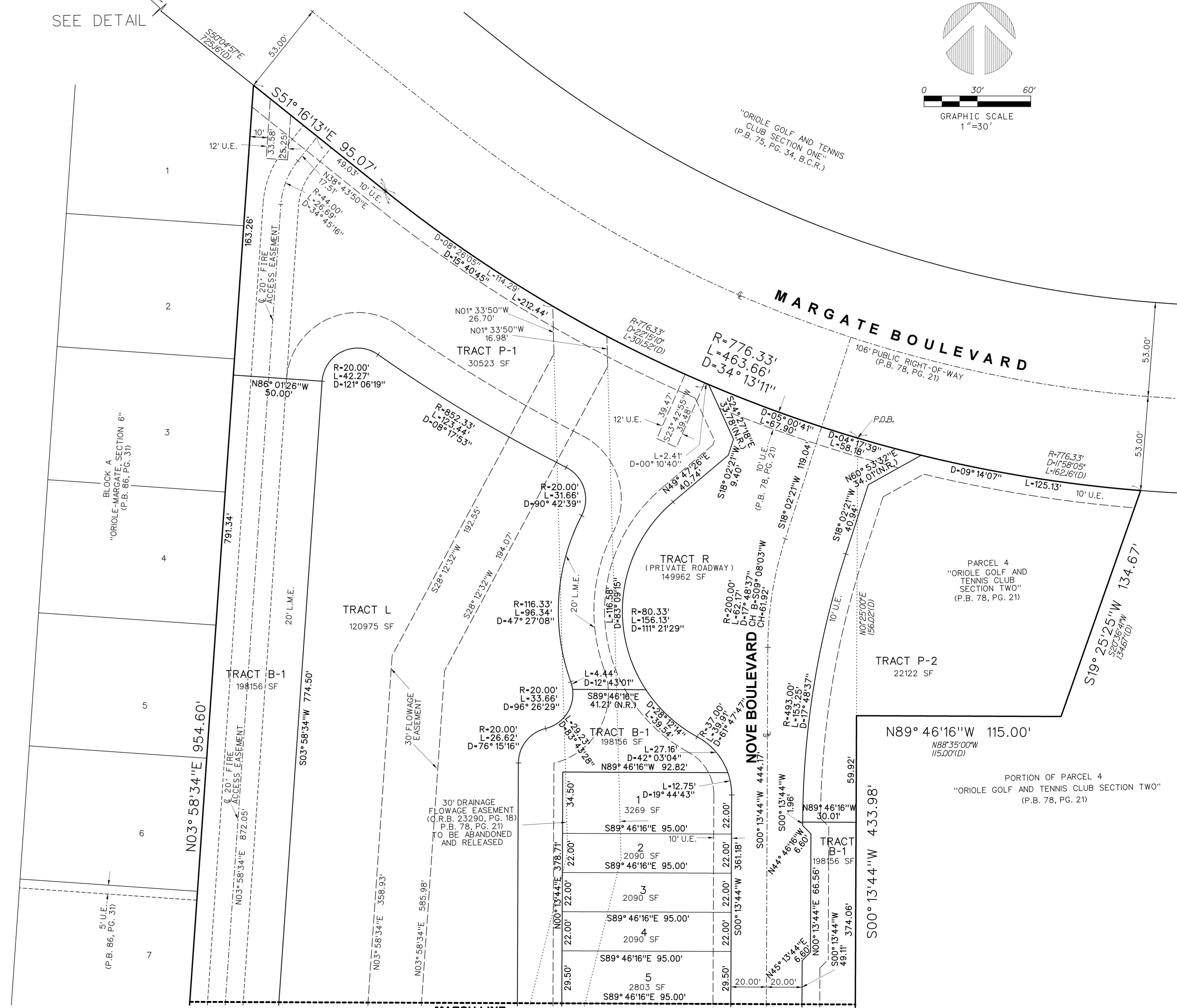

MATCH LINE

SEE SHEET 3

# PERIMETER

## SURVEYING & MAPPING

Prepared by: Jeff S. Hodapp, P.S.M.  
Certificate of Authorization No. LB7264  
947 Clint Moore Road  
Boca Raton, Florida 33487  
Tel: (561) 241-9988  
Fax: (561) 241-5182

# NOVE OF MARGATE

A SUBDIVISION RESURVEY OF PARCEL 3 AND A PORTION OF PARCEL 4, "ORIOLE GOLF AND TENNIS CLUB SECTION TWO"  
ACCORDING TO THE PLAT THEREOF AS RECORDED IN PLAT BOOK 78 PAGE 21 OF THE PUBLIC RECORDS  
OF BROWARD COUNTY, FLORIDA. BEING A PORTION OF SECTION 35 TOWNSHIP 48 SOUTH, RANGE 41 EAST  
CITY OF MARGATE, BROWARD COUNTY, FLORIDA.

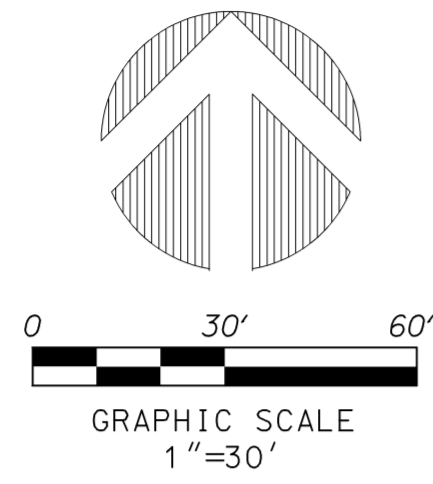

### ABBREVIATIONS:

- B.C.R. . . . . BROWARD COUNTY RECORDS
- CONC. . . . . CONCRETE
- D . . . . . DELTA (CENTRAL ANGLE)
- D.E. . . . . DRAINAGE EASEMENT
- F.P.L. . . . . FLORIDA POWER & LIGHT CO.
- L . . . . . ARC LENGTH
- L.B. . . . . LICENSED BUSINESS
- L.S. . . . . LICENSED SURVEYOR
- MON. . . . . MONUMENT
- O.R.B. . . . . OFFICIAL RECORDS BOOK
- P.B. . . . . PLAT BOOK
- P.G. . . . . PAGE
- P.O.B. . . . . POINT OF BEGINNING
- P.O.C. . . . . POINT OF COMMENCEMENT
- P.R.M. . . . . PERMANENT REFERENCE MONUMENT
- P.S.M. . . . . PROFESSIONAL SURVEYOR & MAPPER
- R . . . . . RADIUS
- R/W . . . . . RIGHT-OF-WAY
- SF . . . . . SQUARE FEET
- U.E. . . . . UTILITY EASEMENT
- N/D . . . . . NAIL AND DISK
- P.D.E. . . . . PUBLIC DRAINAGE EASEMENT
- L.M.E. . . . . LAKE MAINTENANCE EASEMENT
- N.R. . . . . NON-RADIAL

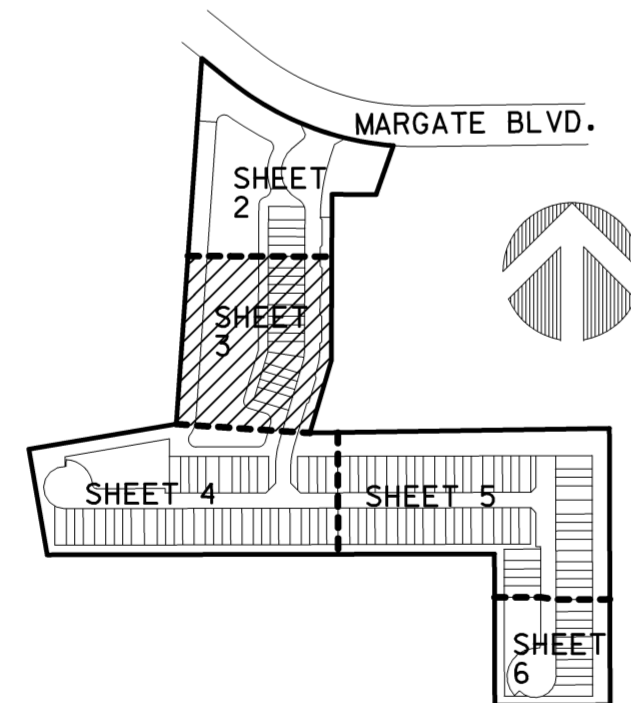

KEY MAP  
NOT TO SCALE

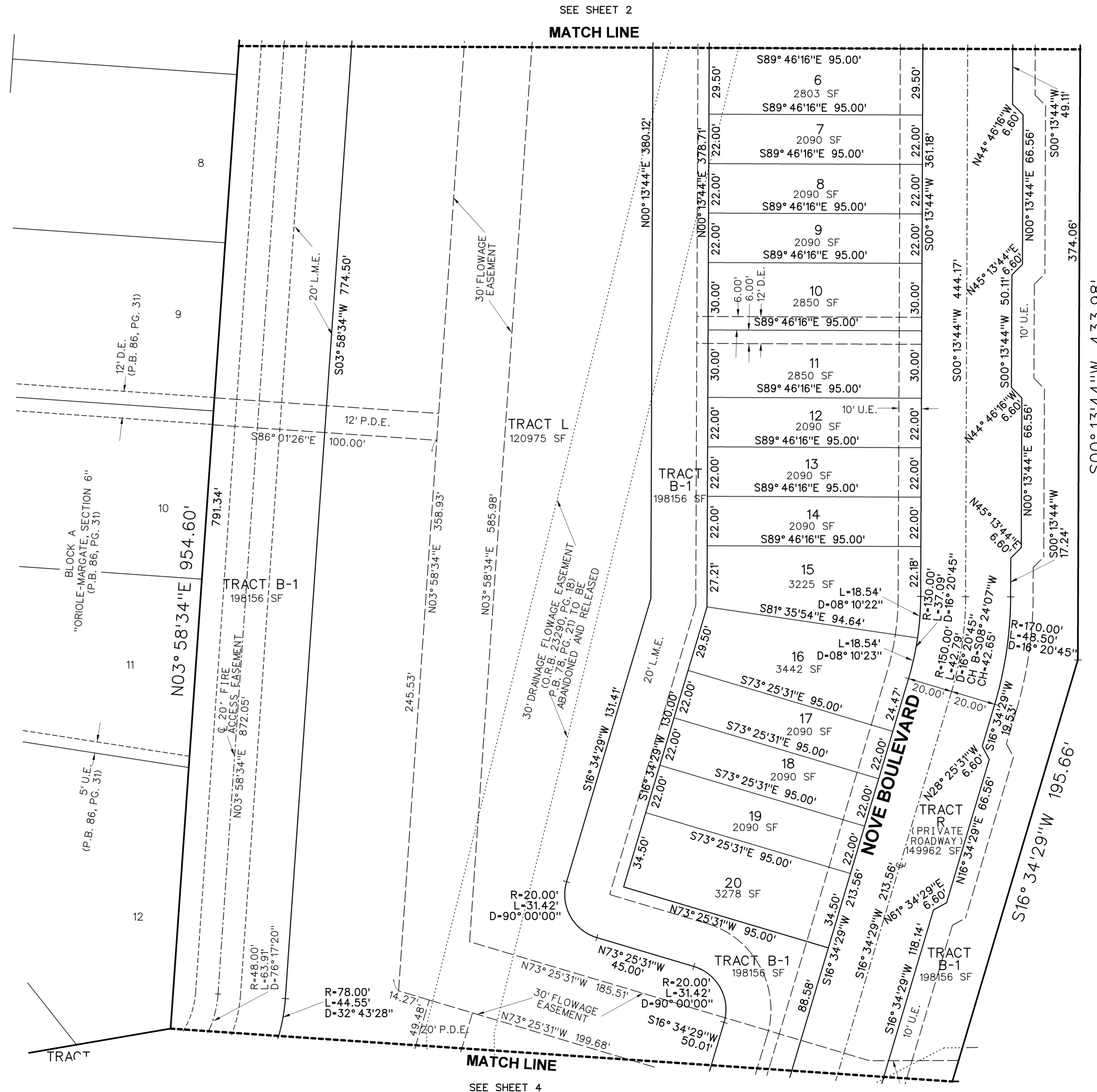

SEE SHEET 2

MATCH LINE

SEE SHEET 4

PORTION OF PARCEL 4  
"ORIOLE GOLF AND TENNIS CLUB SECTION TWO"  
(P.B. 78, PG. 21)



SURVEYING & MAPPING  
Prepared by: Jeff S. Hodapp, P.S.M.  
Certificate of Authorization No. LB7264  
947 Clint Moore Road  
Boca Raton, Florida 33487  
Tel: (561) 241-9988  
Fax: (561) 241-5182

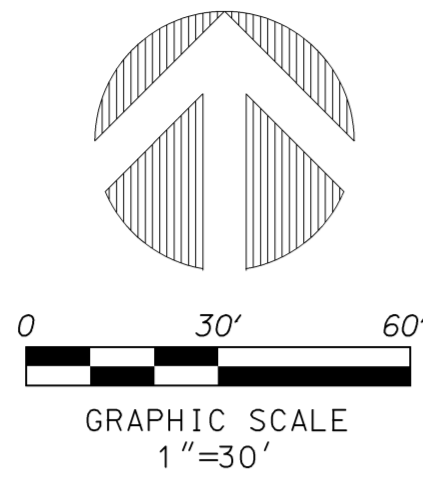

# NOVE OF MARGATE

A SUBDIVISION RESURVEY OF PARCEL 3 AND A PORTION OF PARCEL 4, "ORIOLE GOLF AND TENNIS CLUB SECTION TWO" ACCORDING TO THE PLAT THEREOF AS RECORDED IN PLAT BOOK 78 PAGE 21 OF THE PUBLIC RECORDS OF BROWARD COUNTY, FLORIDA. BEING A PORTION OF SECTION 35 TOWNSHIP 48 SOUTH, RANGE 41 EAST CITY OF MARGATE, BROWARD COUNTY, FLORIDA.

- ABBREVIATIONS:**
- B.C.R. - BROWARD COUNTY RECORDS
  - CONC. - CONCRETE
  - D.C.A. - DELTA (CENTRAL ANGLE)
  - D.E. - DRAINAGE EASEMENT
  - F.P.L. - FLORIDA POWER & LIGHT CO.
  - L.B. - LICENSED BUSINESS
  - L.S. - LICENSED SURVEYOR
  - MON. - MONUMENT
  - O.R.B. - OFFICIAL RECORDS BOOK
  - P.B. - PLAT BOOK
  - P.G. - PAGE
  - P.O.B. - POINT OF BEGINNING
  - P.O.C. - POINT OF COMMENCEMENT
  - P.R.M. - PERMANENT REFERENCE MONUMENT
  - P.S.M. - PROFESSIONAL SURVEYOR & MAPPER
  - R. - RADIUS
  - R/W - RIGHT-OF-WAY
  - SF - SQUARE FEET
  - U.E. - UTILITY EASEMENT
  - N/D - NAIL AND DISK
  - P.D.E. - PUBLIC DRAINAGE EASEMENT
  - L.M.E. - LAKE MAINTENANCE EASEMENT
  - N.R. - NON-RADIAL

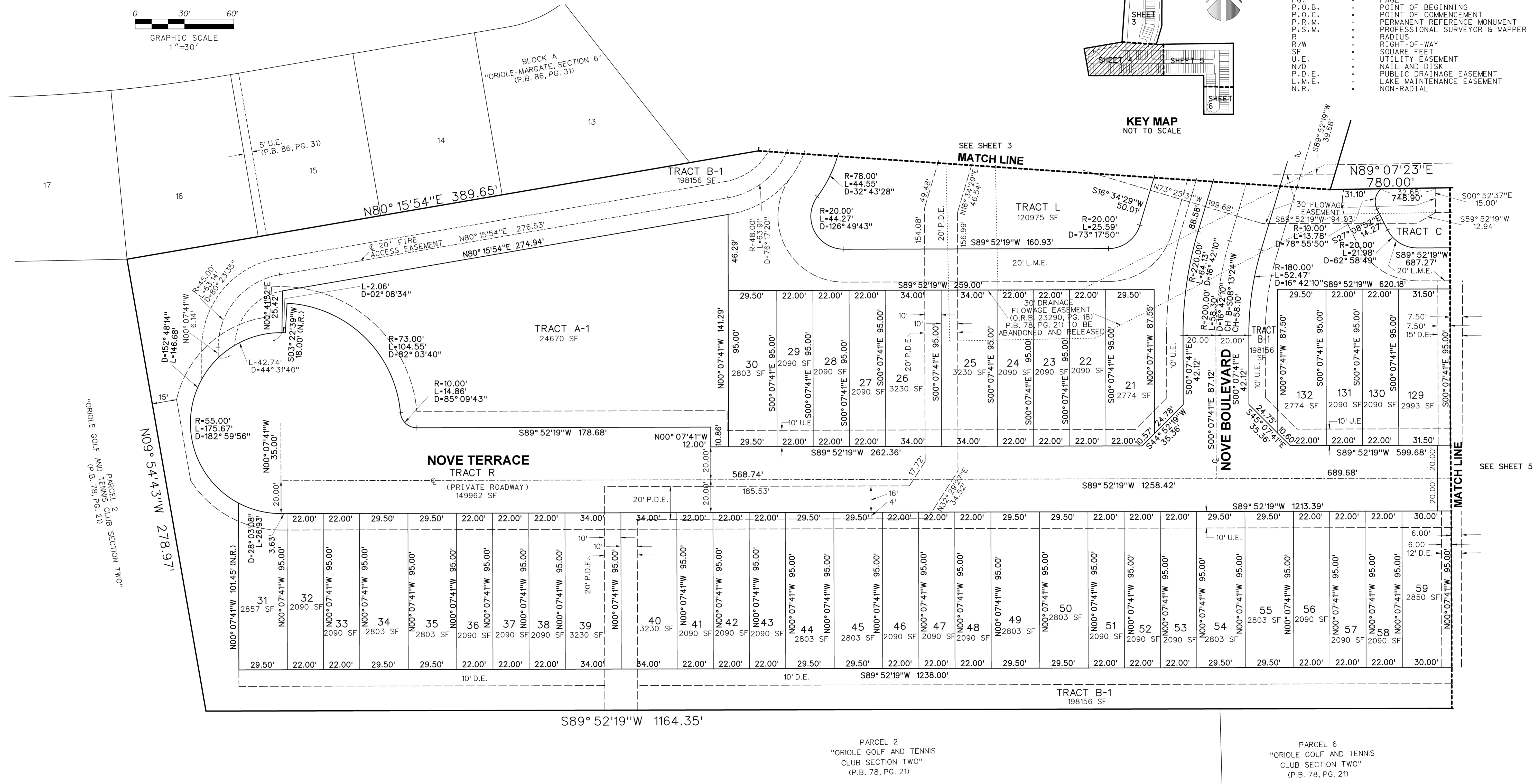
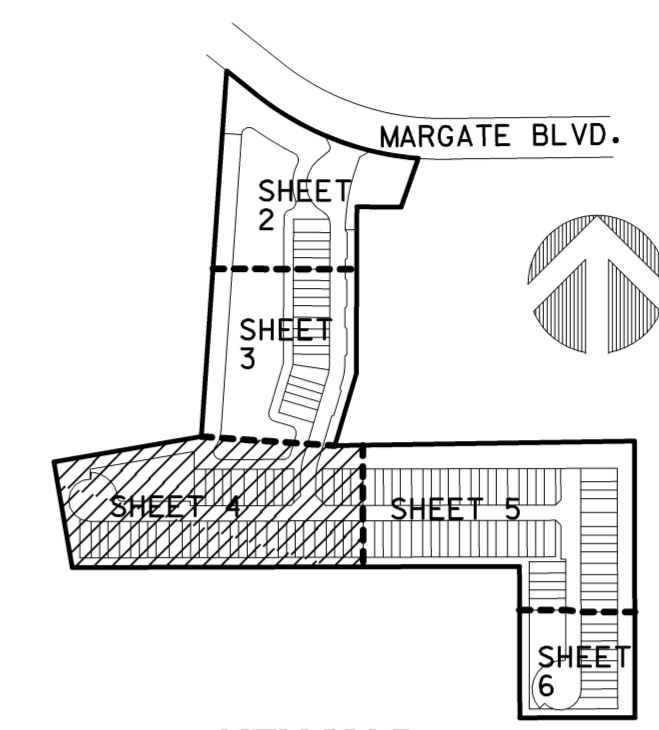

PARCEL 2  
"ORIOLE GOLF AND TENNIS CLUB SECTION TWO"  
(P.B. 78, PG. 21)

PARCEL 2  
"ORIOLE GOLF AND TENNIS CLUB SECTION TWO"  
(P.B. 78, PG. 21)

PARCEL 6  
"ORIOLE GOLF AND TENNIS CLUB SECTION TWO"  
(P.B. 78, PG. 21)

# PERIMETER

## SURVEYING & MAPPING

Prepared by: Jeff S. Hodapp, P.S.M.  
Certificate of Authorization No. LB7264  
947 Clint Moore Road  
Boca Raton, Florida 33487  
Tel: (561) 241-9988  
Fax: (561) 241-5182

# NOVE OF MARGATE

A SUBDIVISION RESURVEY OF PARCEL 3 AND A PORTION OF PARCEL 4, "ORIOLE GOLF AND TENNIS CLUB SECTION TWO"  
ACCORDING TO THE PLAT THEREOF AS RECORDED IN PLAT BOOK 78 PAGE 21 OF THE PUBLIC RECORDS  
OF BROWARD COUNTY, FLORIDA. BEING A PORTION OF SECTION 35 TOWNSHIP 48 SOUTH, RANGE 41 EAST  
CITY OF MARGATE, BROWARD COUNTY, FLORIDA.

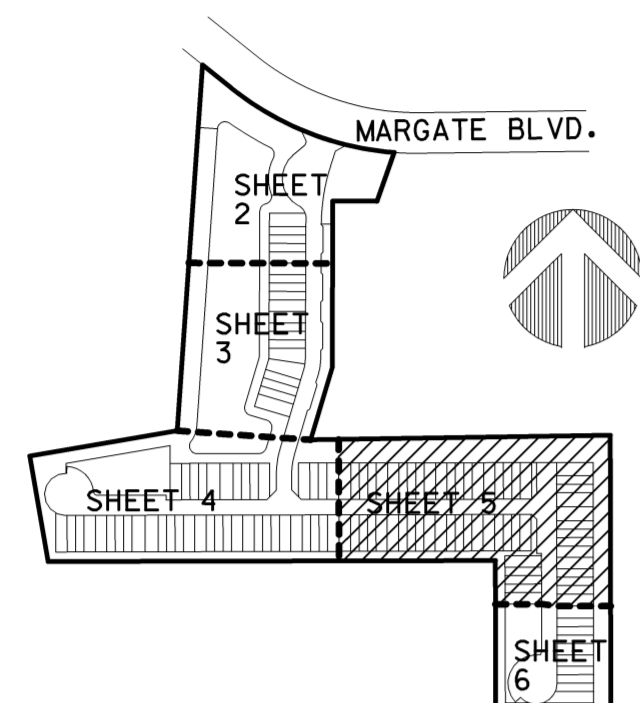
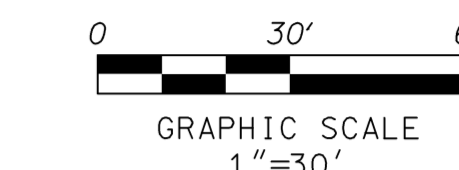
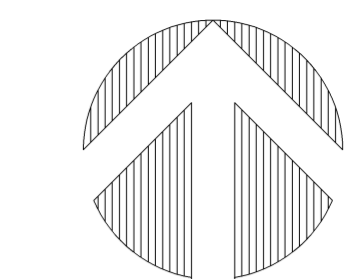

KEY MAP  
NOT TO SCALE

PORTION OF PARCEL 4  
"ORIOLE GOLF AND TENNIS CLUB SECTION TWO"  
(P.B. 78, PG. 21)

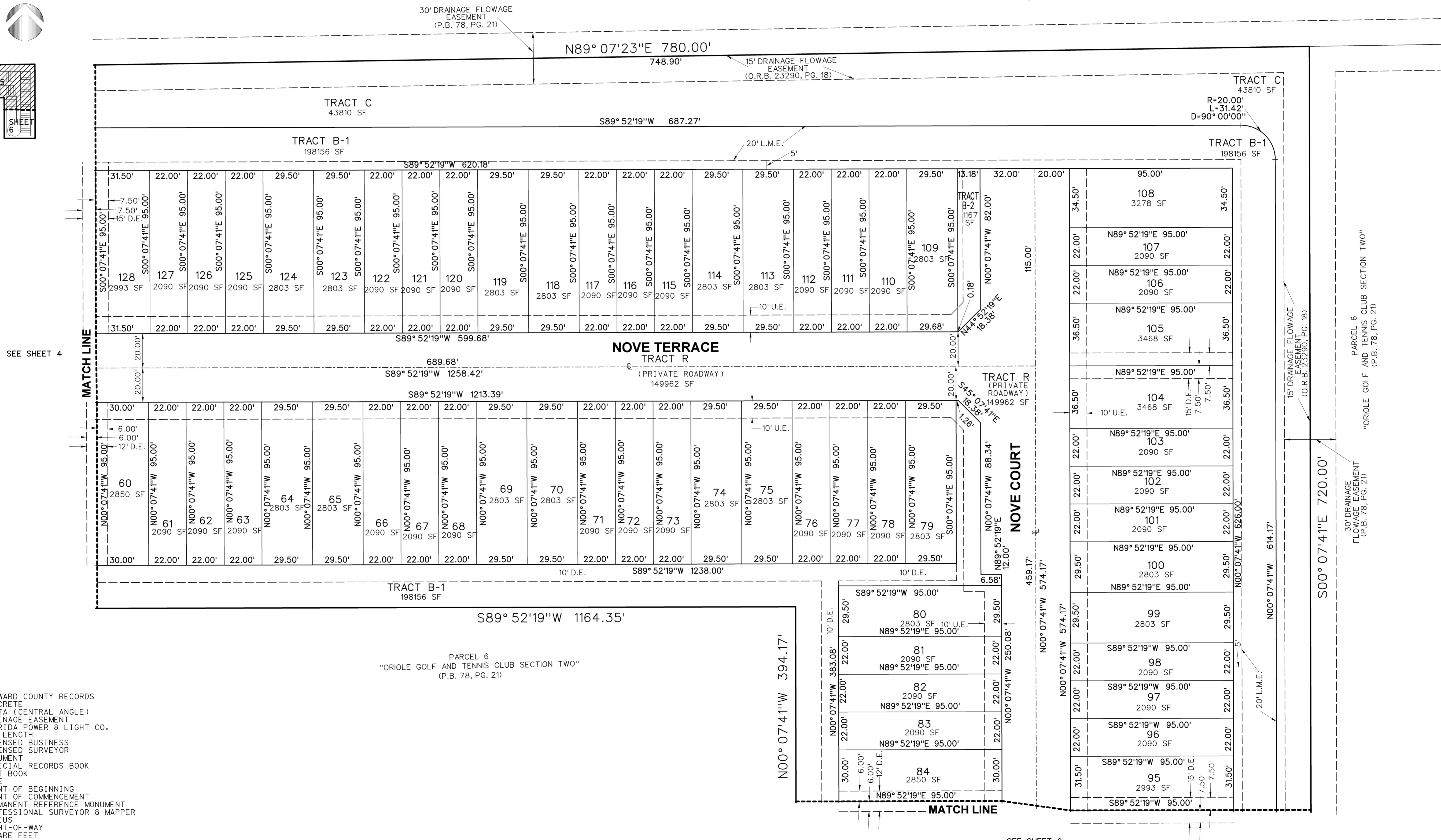

SEE SHEET 4

SEE SHEET 6

### ABBREVIATIONS:

- B.C.R. . . . . BROWARD COUNTY RECORDS
- CONC. . . . . CONCRETE
- DELTA (CENTRAL ANGLE)
- D.E. . . . . DRAINAGE EASEMENT
- F.P.L. . . . . FLORIDA POWER & LIGHT CO.
- L . . . . . ARC LENGTH
- L.B. . . . . LICENSED BUSINESS
- L.S. . . . . LICENSED SURVEYOR
- MON. . . . . MONUMENT
- O.R.B. . . . . OFFICIAL RECORDS BOOK
- P.B. . . . . PLAT BOOK
- PG. . . . . PAGE
- P.O.B. . . . . POINT OF BEGINNING
- P.O.C. . . . . POINT OF COMMENCEMENT
- P.R.M. . . . . PERMANENT REFERENCE MONUMENT
- P.S.M. . . . . PROFESSIONAL SURVEYOR & MAPPER
- R . . . . . RADIUS
- R/W . . . . . RIGHT-OF-WAY
- SF . . . . . SQUARE FEET
- U.E. . . . . UTILITY EASEMENT
- N/D . . . . . NAIL AND DISK
- P.D.E. . . . . PUBLIC DRAINAGE EASEMENT
- L.M.E. . . . . LAKE MAINTENANCE EASEMENT
- N.R. . . . . NON-RADIAL



Prepared by: Jeff S. Hodapp, P.S.M.  
Certificate of Authorization No. LB7264  
947 Clint Moore Road  
Boca Raton, Florida 33487  
Tel: (561) 241-9988  
Fax: (561) 241-5182

# NOVE OF MARGATE

A SUBDIVISION RESURVEY OF PARCEL 3 AND A PORTION OF PARCEL 4, "ORIOLE GOLF AND TENNIS CLUB SECTION TWO"  
ACCORDING TO THE PLAT THEREOF AS RECORDED IN PLAT BOOK 78 PAGE 21 OF THE PUBLIC RECORDS  
OF BROWARD COUNTY, FLORIDA. BEING A PORTION OF SECTION 35 TOWNSHIP 48 SOUTH, RANGE 41 EAST  
CITY OF MARGATE, BROWARD COUNTY, FLORIDA.

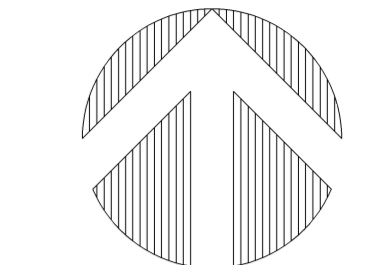

0 30' 60'  
GRAPHIC SCALE  
1"=30'

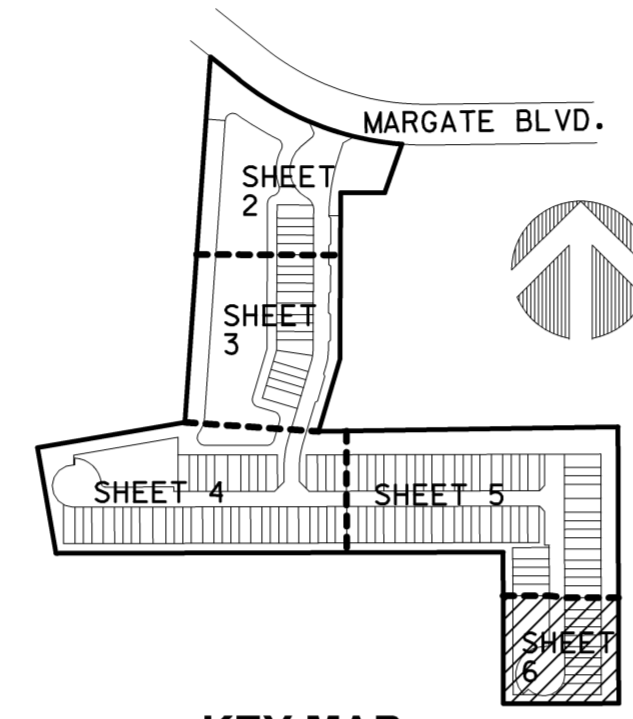

KEY MAP  
NOT TO SCALE

### ABBREVIATIONS:

- B.C.R. . . . . BROWARD COUNTY RECORDS
- CONC. . . . . CONCRETE
- D . . . . . DELTA (CENTRAL ANGLE)
- D.E. . . . . DRAINAGE EASEMENT
- F.P.L. . . . . FLORIDA POWER & LIGHT CO.
- L . . . . . ARC LENGTH
- L.B. . . . . LICENSED BUSINESS
- L.S. . . . . LICENSED SURVEYOR
- MON. . . . . MONUMENT
- O.R.B. . . . . OFFICIAL RECORDS BOOK
- P.B. . . . . PLAT BOOK
- PG. . . . . PAGE
- P.O.B. . . . . POINT OF BEGINNING
- P.O.C. . . . . POINT OF COMMENCEMENT
- P.R.M. . . . . PERMANENT REFERENCE MONUMENT
- P.S.M. . . . . PROFESSIONAL SURVEYOR & MAPPER
- R . . . . . RADIUS
- R/W . . . . . RIGHT-OF-WAY
- SF . . . . . SQUARE FEET
- U.E. . . . . UTILITY EASEMENT
- N/D . . . . . NAIL AND DISK
- P.D.E. . . . . PUBLIC DRAINAGE EASEMENT
- L.M.E. . . . . LAKE MAINTENANCE EASEMENT
- N.R. . . . . NON-RADIAL

PARCEL 6  
"ORIOLE GOLF AND TENNIS  
CLUB SECTION TWO"  
(P.B. 78, PG. 21)

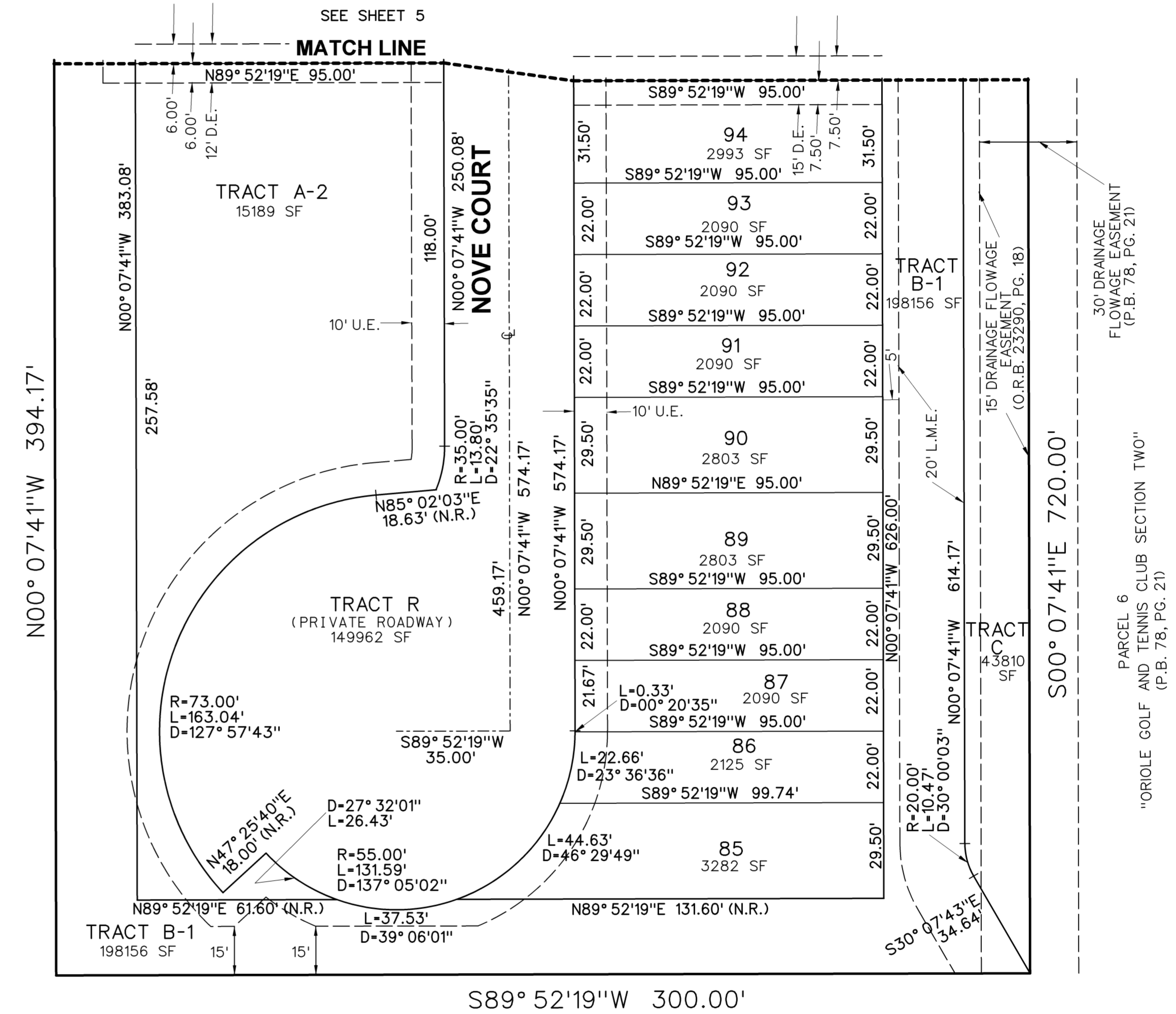

PARCEL 6  
"ORIOLE GOLF AND TENNIS  
CLUB SECTION TWO"  
(P.B. 78, PG. 21)

# PERIMETER

**SURVEYING & MAPPING**  
 Prepared by: Jeff S. Hodapp, P.S.M.  
 Certificate of Authorization No. LB7264  
 947 Clint Moore Road  
 Boca Raton, Florida 33487  
 Tel: (561) 241-9988  
 Fax: (561) 241-5182







# NOVE OF MARGATE

A SUBDIVISION RESURVEY OF PARCEL 3 AND A PORTION OF PARCEL 4, "ORIOLE GOLF AND TENNIS CLUB SECTION TWO"  
 ACCORDING TO THE PLAT THEREOF AS RECORDED IN PLAT BOOK 78 PAGE 21 OF THE PUBLIC RECORDS  
 OF BROWARD COUNTY, FLORIDA. BEING A PORTION OF SECTION 35 TOWNSHIP 48 SOUTH, RANGE 41 EAST  
 CITY OF MARGATE, BROWARD COUNTY, FLORIDA.

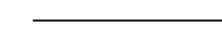
### ABBREVIATIONS:

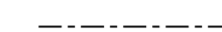
- B.C.R. - BROWARD COUNTY RECORDS
- CONC. - CONCRETE
- D. - DELTA (CENTRAL ANGLE)
- D.E. - DRAINAGE EASEMENT
- F.P.L. - FLORIDA POWER & LIGHT CO.
- L. - ARC LENGTH
- L.B. - LICENSED BUSINESS
- L.S. - LICENSED SURVEYOR
- MON. - MONUMENT
- O.R.B. - OFFICIAL RECORDS BOOK
- P.B. - PLAT BOOK
- PG. - PAGE
- P.O.B. - POINT OF BEGINNING
- P.O.C. - POINT OF COMMENCEMENT
- P.R.M. - PERMANENT REFERENCE MONUMENT
- P.S.M. - PROFESSIONAL SURVEYOR & MAPPER
- R. - RADIUS
- R/W - RIGHT-OF-WAY
- SF. - SQUARE FEET
- U.E. - UTILITY EASEMENT
- N/D - NAIL AND DISK
- P.D.E. - PUBLIC DRAINAGE EASEMENT
- L.M.E. - LAKE MAINTENANCE EASEMENT
- N.R. - NON-RADIAL

### LEGEND:

-  PROJECT BOUNDARY
-  LOT OR TRACT LINE
-  EASEMENT LINE
-  CENTERLINE
-  EASEMENT TO BE RELEASED
-  EASEMENT TO BE DEDICATED
-  EXISTING WATER LOCATION

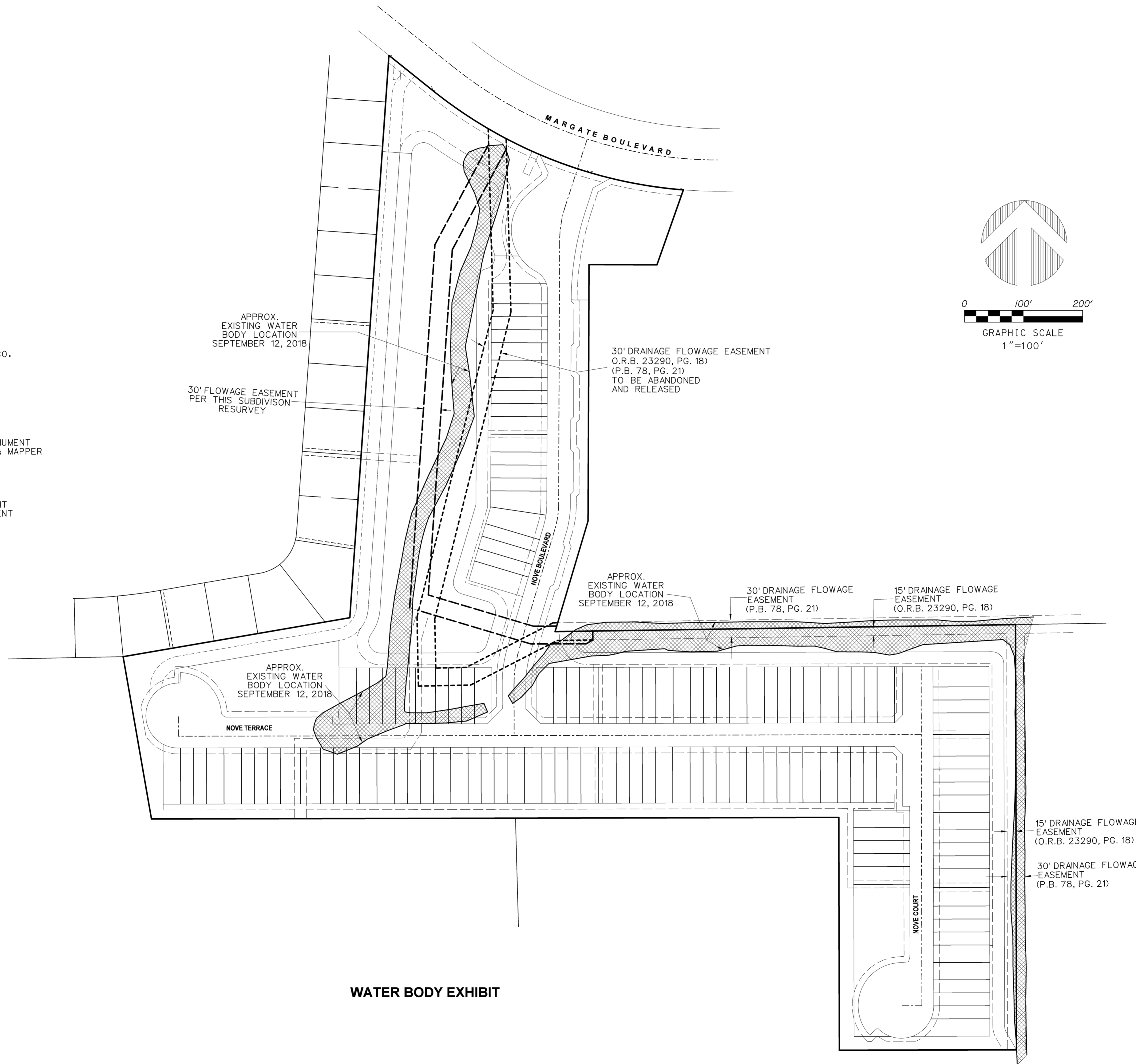

WATER BODY EXHIBIT